

CENTRAL HIGH SCHOOL

CURRICULUM GUIDE

2012 – 2013



Important Dates

- February 3rd-8th CHS Counselors meet with current freshmen, sophomores, and juniors to register for classes.
- February 22nd CHS Counselors meet with 8th Grade students at Prairie Knolls Middle School to register for classes.
- February 24th CHS Counselors meet with 8th Grade students at Central Middle School to register for classes.

TABLE OF CONTENTS

General Information.....	3
Career/Tech Education.....	8
Humanities: Fine Arts/Foreign Language.....	13
English.....	17
Mathematics.....	21
Physical Education/Health/Drivers Education.....	24
Science.....	26
Social Studies.....	29
Elgin Community College Partnership for College and Career Success (Formerly Tech Prep).....	32
Fox Valley Career Center.....	34

CHANGES TO THE CURRICULUM

New Courses Offered in 2012-2013

Course 1115 Advanced Placement (AP) Computer Science

Changes in Course Names/Prerequisites

Course 1025	This course (Entrepreneurship) will now be open to Juniors as well as Seniors.
Course 1101	This course (Computer Programming 2) will no longer be offered. Instead, Course 1100 (Intro. to Computer Programming) will be repeatable.
Course 1106	This course (Web Design 2) will no longer be offered. Instead, Course 1105 (Web Design) will be repeatable.
Course 1052	This course (Multimedia Production) will now be open to all grade levels and be repeatable.
Course 1054	This course (Multimedia Production 2) will no longer be offered. Instead, Course 1052 (Multimedia Production) will be repeatable.
Course 1210	This course (Animal Science) will now be open to Sophomores as well as Juniors and Seniors.
Course 1211	This course (Plant Science) will now be open to Sophomores as well as Juniors and Seniors.
Course 1205	This course (Veterinary Technology) will now be open to Sophomores as well as Juniors and Seniors.
Course 1206	This course (Veterinary Technology 2) will now be open to Sophomores as well as Juniors and Seniors.
Course 2056	The name of this course (Introduction to 2-D Art) will now be Introduction to Drawing & Painting.
Course 2061	The name of this course (Introduction to 3-D Art) will now be Introduction to Sculpture & Ceramics.
Courses 2065/2066	These courses (Drawing 1 & 2) will be condensed into the new course Intermediate Drawing.
Courses 2068/ 2069/ 2081/2082	These courses (Ceramics 1 & 2, Sculpture 1 & 2) will be condensed into the new course Intermediate Sculpture & Ceramics
Course 2070	This course (Photography 1) will now be open to Freshmen as well as all other grade levels.
Course 2075	This course (Photography 2) will now be open to Sophomores as well as Juniors and Seniors.
Courses 2085/2086	These courses (Painting1 & 2) will be condensed into the new course Intermediate Painting.
Courses 2100/2101	These courses (2D & 3D Commercial Art) will be condensed into the new course Digital Photography/Graphic Design
Course 3012	This course (Accelerated Spanish 3) will no longer be offered.
Course 4000	This course (English 1) will now be Freshman English
Course 4005	This course (English 1 Double Block) will now be Freshman English Double Block
Course 4044	This course (English Literature) will now be British Literature
Course 4085	This course (Careers & English) will now be Writing for College & Careers

GENERAL INFORMATION

HOW TO USE THIS GUIDE

This guide has been created to help you register for classes. It contains most of the information you will need to make your course selections for the upcoming school year. As you begin the process of selecting your courses, pay careful attention to the prerequisites and grade levels required for the course you are interested in to ensure you are registering only for courses for which you are eligible. The number of credit hours earned for a class are indicated.

Be sure to carefully look at graduation requirements and college entrance requirements to assist you in choosing the right courses that will help you meet your future goals. Please see your counselor to assist you in this process.

Please note that certain courses require teacher approval or a mandatory teacher meeting. You are encouraged to discuss class placement with your counselor and current teachers, but be aware that signing up for a class does not guarantee enrollment in that class. Also, **all students must have a parent/guardian's signature on the registration sheet.**

Please contact your assigned counselor by e-mail or phone if you have questions or want to schedule an appointment:

Last Names A-G: Mrs. Arlene Knewitz (847-464-6037, aknewitz@burlington.k12.il.us)
Last Names H-Pan: Mr. Jonathan Young (847-464-0025, jyoung@burlington.k12.il.us)
Last Names Pao-Z: Mrs. Cheryl Wessels (847-464-6036, cwessels@burlington.k12.il.us)

GRADUATION REQUIREMENTS

The objective of every student should be to earn a high school diploma. Before receiving a diploma, a student must successfully complete all graduation requirements as specified by the Central Community Unit School District 301 Board of Education, the Illinois State Board of Education, and *The School Code of Illinois*. Students receive one half credit for each class in which they receive a passing grade, except as indicated in this guide. A total of 29 credits are required for graduation from Central High School. This total may be adjusted down if a student transfers to Central High School from another school. Graduation credits must include the following:

English	4 credits (8 semesters)
Mathematics	3 credits (6 semesters)
Science	3 credits
Social Studies	3 credits
Humanities (Fine Arts/Foreign Language)	2-3 credits*
Career/Tech Education	2 credits
Physical Education (P.E.)	3.5 credits
Health	1 credit
Electives	6.5-7.5 credits
Total	29 credits

*3 credits in one subject area or 2 credits in more than one subject area with a minimum of 1 credit in each of two areas.

Specific Course Requirements (The following courses MUST be completed in order for students to graduate from Central High School)

Freshman English (or Honors Fresh. English or Fresh. English DB)	Biology (or Applied Biology or Accelerated Biology)
American Literature (or Honors American Lit. or American Lit. Studies)	Earth Science 1
Algebra 1 (Single Block, Double Block, or General Algebra)	Health 1 & 2
Consumer Education (or equivalent – see Page 6)	Sociological Dynamics of the Individual & Family
Introduction to Physical Science (waived if student took Accel. Biology)	American Government (or AP Government)
United States History (or AP U.S. History)	Modern World History (or Honors World History)

Credits From Other Institutions: Other than credits transferred from another high school when a student establishes residence in the district, students may earn no more than two credits from a pre-approved program such as a correspondence course.

ADVANCED PLACEMENT (AP) COURSES

Advanced Placement (AP) courses are college preparatory in nature and prepare students for advanced placement tests which are administered in May of each school term. In these challenging courses, college level material is studied and students have the opportunity to demonstrate college level achievement. Sufficiently high scores on an AP test may enable a student to earn college credit from many colleges and universities. If such credit is a major concern, the student should check with his/her chosen college or university to determine if it grants credit for the test. College credit is not an automatic outcome of passing the AP course. Each advanced placement test has a fee. The following Advanced Placement courses are offered at Central High School:

*AP United States History	AP U.S. Government & Politics	AP Psychology
AP English Literature & Composition	AP English Language & Composition	AP Computer Science
AP Calculus AB	AP Calculus BC	AP Statistics
*AP Biology	*AP Chemistry	*AP Physics
AP Studio Art: Drawing	AP Studio Art 2D-Design	AP Studio Art 3D-Design
AP Spanish Language	AP German Language	

Note: All Advanced Placement courses are weighted to count more heavily in the calculation of Grade Point Average (GPA)

**These classes are "Early Bird" classes and start at 7:30AM; these courses earn 1.25 credits per year.*

PLACEMENT IN FRESHMAN CLASSES

Except as indicated elsewhere in this guide, as a general rule, initial placement in freshman courses will be based on a combination of student performance on the EXPLORE test given in 8th Grade, articulation between the high school and middle schools, and, in certain select cases, student performance on diagnostic tests.

PREREQUISITES

A prerequisite may be a course, a grade in a course, or a year in school. If a course has a prerequisite, it will be listed just below the course name in this guide. You must meet the prerequisites required for a course before you are allowed to enroll in it. However, if you have not met the grade requirements to enroll in the course, you may also seek a grade prerequisite waiver. Please see your counselor for this form.

ELGIN COMMUNITY COLLEGE (ECC) ARTICULATED CREDIT

Students may receive both high school credit and Elgin Community College (ECC) credit for some courses taught at Central High School, called articulated credit. Articulated credit improves a student's education by saving time, money, and the repeating of course work already mastered. Students who earn an A or B in an articulated course at Central High School and then enroll in Elgin Community College in a degree-seeking program within 27 months of graduation from Central High School will automatically receive Elgin Community College credits. Courses approved for articulated credit between Central High School and Elgin Community College are as follows:

<u>Central High School</u>	<u>Elgin Community College</u>
Accounting 1	ACC 100
Accounting 2	ACC 101
Keyboarding/Software Applications	OAT 101
Computer Keyboarding 2	OAT 102
Microsoft Word Certification	OAT 140
Microsoft Excel Certification	OAT 141
CADD 3	CAD 108
Child Growth & Development	ECE 174
Introduction to Computer Programming	CIS 105
Web Design 1 or Web Design 2	CIS 147
Criminal Law	CRJ 101
Automotive Technology 1 (Fox Valley)	AUT 151
Automotive Technology 2 (Fox Valley)	AUT 152
Early Childhood Education (Fox Valley)	ECE 124
Health Occupations – Certified Nursing Assistant	NUR 105
Small Engines (Fox Valley)	AUT 100
Welding 1 (Fox Valley)	WEL 101
Welding 2 (Fox Valley)	WEL 102
Fire Science 1 (Fox Valley)	FSS 101
Fire Science 2 (Fox Valley)	FSS 202
Computer Technology – Game Programming & Technologies (Fox Valley)	CIS 147

ELGIN COMMUNITY COLLEGE (ECC) PARTNERSHIP FOR COLLEGE AND CAREER SUCCESS PROGRAM (FORMERLY TECH PREP) – SEE PAGE 32

Seniors, and some juniors, may elect to attend Elgin Community College (ECC) courses during part of the regular school day and earn **both** high school and college credits. Students, on average, complete 6 credit hours per semester. Credits earned through PCCS can give students as much as a one semester “head start” toward earning an Associates Degree from Elgin Community College.

Students enrolled in the PCCS program at ECC will be required to pay for their own books. In addition, if a student should be removed or withdraws from the ECC PCCS program prior to completing the semester, the student will be required to pay for that semester.

To enroll in a PCCS program, students must:

- 1.) Complete comparable courses available at Central High School.
- 2.) Take all preparation and orientation level courses offered at Central High School prior to enrolling in PCCS. The table below lists required prerequisites:

<u>ECC Program</u>	<u>CHS Prerequisite(s)</u>
Accounting	Fund. of Business, Accounting1 & 2
Automotive Services	Tech/Pre-Engineering
Computer & Information Science	Intro. to Computer Programming, Computer Networking/Hardware
Early Childhood Education	Child Growth & Dev., School-Age Child Dev.
Engineering/CAD	Tech/Pre-Engineering, CADD 1 & 2
Entrepreneurship	Fund. of Business and Entrepreneurship or Marketing
Graphic Design	Intro. to 2-D Art
Heating/Air Conditioning/Refrigeration	Tech/Pre-Engineering
Industrial Manufacturing Technology	Tech/Pre-Engineering
Integrated Systems/Maintenance Technology	Tech/Pre-Engineering
Management	Fund. of Business
Marketing & Retail Management	Fund. of Business, Marketing
Multimedia Design	Multimedia Production, Intro. to Drawing/Painting
Office Administration Technology	Keyboarding/Software Applications, Microsoft Word Certification, Microsoft Excel Certification
Paralegal	Civil Law or Criminal Law
Restaurant Management	Fund. of Business
Web Design	Web Design 1; Multimedia Production recommended
Welding	Tech/Pre-Engineering

- 3.) Complete the application forms (available in the Guidance Office)
- 4.) Meet entrance requirements established by ECC for each course. All programs will require taking the COMPASS placement reading test, while others will require additional placement tests. Please see your counselor for details.
- 5.) In addition, when the number of students who sign up for ECC is higher than spots available, student grades and teacher recommendations in the related subject areas shall be considered in deciding who will be able to enroll in any given PCCS program.

FOX VALLEY CAREER CENTER – SEE PAGE 34

Fox Valley Career Center, located at Kaneland High School in Maple Park, is open to a limited number of junior and senior students. Fox Valley offers students a variety of program opportunities that are outlined in more detail on Page 34. Students enrolled in Fox Valley courses will be transported by bus to the Fox Valley Career Center for classes during one of three sessions.

Note: Additional fees and/or tools may be required. Students must provide their own transportation to courses taught at Fox Valley satellite locations.

COURSES IN TWO SUBJECTS AREAS

Some courses at Central High School can be taken for different types of credit. If you choose one of these courses, you must declare at the time of registration what type of credit you wish to receive. The courses which offer these options are:

Introduction to Agricultural Science:	Career/Tech Education or Science
Animal Science:	Career/Tech Education or Science
Plant Science	Career/Tech Education or Science
Veterinary Technology:	Career/Tech Education or Science
Veterinary Technology 2:	Career/Tech Education or Science
Biotechnology	Career/Tech Education or Science
Alternative Energy	Career/Tech Education or Science
Economics:	Social Studies or Career/Tech Education

COURSE LOAD

Students must register for 8 credits each school year (4 per semester). Students taking Advanced Placement, ECC PCCS, or Fox Valley courses may earn less than 8 or more than 8 credits per year depending on the program.

MEETING THE CONSUMER EDUCATION REQUIREMENT

The State of Illinois requires that all high school graduates possess minimum competencies in the area of Consumer Education. At Central High School this competency can be shown in one of three ways:

- 1.) Successfully completing the course Consumer Education.
- 2.) Successfully completing the course Economics.
- 3.) Successfully completing the course Cooperative Education.

Note: As of July 2010, the State of Illinois has discontinued the Illinois Consumer Education Proficiency Test. Therefore, that will no longer be an option for students to meet the Consumer Education requirement.

ART REFUND POLICY

Students dropping an Art class from their schedule after the 8th day of school in the fall will not receive a refund for Art fees paid. This pertains to both first and second semester Art courses.

NCAA FRESHMAN ELIGIBILITY STANDARDS

There are guidelines published and enforced by the National Collegiate Athletic Association (NCAA) which govern eligibility for athletic scholarships at Division I and II colleges. The NCAA judges course work of high school students and determines whether it meets the requirements for a scholarship.

RULES:

Core Courses

- Starting August 1, 2008, 16 core courses will be required for NCAA Division I only. This rule applies to any student first entering any Division I college or university on or after August 1, 2008. See the chart on Page 7 for the breakdown of this 16 core-course requirement.
- 14 core courses are required in NCAA Division II. See the chart on Page 7 for the breakdown of core-course requirements.

PLEASE NOTE: Beginning August 1, 2013, students planning to attend an NCAA Division II institution will be required to complete 16 core courses.

Test Scores

- Division I has a sliding scale for test score and grade-point average.
- Division II has a minimum SAT score requirement of 820 or an ACT sum score of 68.
- The SAT score used for NCAA purposes includes only the critical reading and math sections. The writing section of the SAT is not used.

- The ACT score used for NCAA purposes is a sum of the four sections on the ACT: English, math, reading and science.
- **All SAT and ACT scores must be reported directly to the NCAA Eligibility Center by the testing agency. Test scores that appear on transcripts will no longer be used. When registering for the SAT or ACT, use the Eligibility Center code of 9999 to make sure the score is reported to the eligibility center.**

Grade-Point Average

- Only core courses are used in the calculation of the grade-point average.
- Be sure to look at Central High School’s list of NCAA-approved core courses on the Eligibility Center Web site to make certain that the courses being taken have been approved as core courses. The Web site is www.ncaa.org. The list of approved courses is also provided below.
- Division I grade-point-average requirements are listed on page two of this sheet.
- The Division II grade-point-average requirement is a minimum 2.000.

DIVISION I 16 Core-Course Rule	DIVISION II 14 Core-Course Rule
<p><u>16 Core Courses:</u></p> <p>4 years of English. 3 years of mathematics (Algebra I or higher). 2 years of natural/physical science (1 year of lab if offered by high school). 1 year of additional English, mathematics or natural/physical science. 2 years of social science. 4 years of additional courses (from any area above, foreign language or non-doctrinal religion/philosophy).</p>	<p><u>14 Core Courses:</u></p> <p>3 years of English. 2 years of mathematics (Algebra I or higher). 2 years of natural/physical science (1 year of lab if offered by high school). 2 years of additional English, mathematics or natural/physical science. 2 years of social science. 3 years of additional courses (from any area above, foreign language or non-doctrinal religion/philosophy).</p>

Other Important Information

- Division II has no sliding scale. The minimum core grade-point average is 2.000. The minimum SAT score is 820 (verbal and math sections only) and the minimum ACT sum score is 68.
- 14 Core courses are required for Division II.
- 16 Core courses are required for Division I.
- The SAT combined score is based on the verbal and math sections only. The writing section will not be used.
- SAT and ACT scores must be reported directly to the clearinghouse from the testing agency. Scores on transcripts will not be used.
- Students enrolling at an NCAA Division I or II institution for the first time need to also complete the amateurism questionnaire through the Eligibility Center web site. Students need to request final amateurism certification prior to enrollment.

For more information regarding the rules, please go to www.ncaa.org. Click on “Academics and Athletes” then “Eligibility and Recruiting.” Please call the NCAA Eligibility Center if you have questions: Toll-free number: (877) 262-1492

NCAA-Approved Courses

The following Central High School courses have been approved by the NCAA as meeting the core course requirements: Freshman English, Freshman English Double Block, Advanced Composition, Honors American Literature, American Literature, Bible as Literature, College Prep English, AP English Language & Composition, British Literature, Contemporary Literature, AP English Literature & Composition, Journalism 1, Journalism 2, Sci-Fi/Fantasy Lit., Speech 1, Speech 2, Women in Literature, World Literature, Writer’s Craft, Algebra 1, Algebra 1 Double Block, Algebra 2, Algebra 2 Double Block, Accelerated Algebra 2, College Algebra, Geometry, Geometry Double Block, Accelerated Geometry, Trigonometry, Pre-Calculus, Calculus, AP Calculus AB, AP Calculus BC, Probability & Statistics, Transition to College Math, Intro. to Physical Science, Biology, Accelerated Biology, AP Biology, Chemistry, Accelerated Chemistry, AP Chemistry, Physics, AP Physics, Earth Science, Earth Science 2, Current Science Topics, Astronomy, Anatomy & Physiology (Tech Prep), American Government, AP U.S. Government & Politics, US History, AP US History, Modern World History (regular and Honors), Adventures in Social Studies, Civil Law, Criminal Law, Criminal Justice Tech Prep 1, Criminal Justice Tech Prep 2, Economics, Psychology, Psychology 2, AP Psychology, Sociology, Sociological Dynamics of the Individual & Family, Spanish 1, Spanish 2, Spanish 3, Spanish 4, AP Spanish, German 1, German 2, German 3, German 4, and AP German.

1040 COMPUTER KEYBOARDING 3
Semester Course 0.5 Credits
Grade Level: 9-12 Prerequisite: Keyboarding 2

Students develop an employable production rate for the keyboarding of business letters, reports, and statistical data. Emphasis is placed on correctly prioritizing work and developing a high degree of speed and accuracy. Proofreading, editing, and language skills are reinforced.

1050 COMPUTER APPLICATIONS
Semester Course 0.5 Credits
Grade Level: 9-12

Get acquainted with and trained in the basic use of business computer packages (Microsoft Office), including word processing (Word), database management (Access), spreadsheets (Excel), presentations (PowerPoint), desktop publishing (Publisher), and Internet-access methods. Serves as an introduction to other computer application courses.

1042 MICROSOFT WORD CERTIFICATION
Semester Course 0.5 Credits
Grade Level: 9-12

Learn the **advanced** features of Microsoft Word through creating and editing a word document and templates, creating a research paper, creating a cover letter and a resume, creating a document with a title page, table chart, and watermark, generating form letters, mailing labels, and directories, creating a professional newsletter, working with document sharing tools, a master document, a table of contents, and an index, creating and enhancing an online form, and working with macros, document security, and XML. Will prepare student to take the Microsoft Office Specialist Certification Word 2007 exam. *Articulates with Elgin Community College OAT140 and OAT240.*

1043 MICROSOFT EXCEL CERTIFICATION
Semester Course 0.5 Credits
Grade Level: 9-12

Learn the **advanced** features of Microsoft Excel through creating a worksheet and an embedded chart, working with formulas, formatting, and web queries, working with what-if analysis, charting, and large worksheets, working with financial functions, data tables, and amortization schedules, creating, sorting, and querying a table, creating templates and working with multiple worksheets and workbooks, using macros and visual basic for applications (VBA) with Excel, working with formula auditing, data validation, and complex problem solving, and importing data, working with PivotCharts, PivotTables, and Trendlines. Will prepare student for using Excel in science and business applications. Will prepare student to take the Microsoft Office Specialist Certification Excel 2007 exam. *Articulates with Elgin Community College OAT141 and OAT241.*

1052 MULTI-MEDIA PRODUCTION
Year Course 1 Credit
Grade Level: 9-12

Students will be part of a production team that produces a multi-media yearbook. Will integrate sound, video, graphics, and text. Students will learn Desktop Publishing, digital manipulation of audio and video material, and develop a marketing campaign. *Course may be repeated.*

1090 COMPUTER NETWORKING/HARDWARE
Year Course 1 Credit
Grade Level: 11-12

Students will develop skills to install, setup, configure, test, troubleshoot, and maintain personal computers and peripherals. Will learn the skills needed to setup, configure, test, troubleshoot, maintain, and administer a data network. Will learn basic operating system commands, install and configure networks, set up user rights and accounts and establish user security and permissions.

1105 WEB DESIGN
Semester Course 0.5 Credits
Grade Level: 10-12

Introduces the basics of creating and publishing web pages on the Internet. Learn HTML and how to use a WYSIWYG web page editor. Topics include the basic markup codes, linking to other pages, graphics, lists, tables, multimedia, and forms. Students will create their own website. *Course may be repeated. Articulates with Elgin Community College CIS147.*

1100 INTRODUCTION TO COMPUTER PROGRAMMING
Semester Course 0.5 Credits
Grade Level: 11-12 Prerequisite: Algebra I & Keyboarding

An introductory course designed to familiarize students with the general concepts of programming. Students will learn program design and structured programming techniques. *Course may be repeated. Articulates with Elgin Community College CIS105.*

1115 AP COMPUTER SCIENCE
Year Course 1 Credit
Grade Level: 11-12 Prerequisite: Algebra 2 & Intro. to Comp. Programming recommended

Advanced Placement Computer Science is a rigorous, college-level course designed to prepare students for the AP[®] Computer Science A examination using the Java programming language. This course emphasizes object-oriented programming methodology with a concentration on problem solving and algorithm development. It also includes the study of data structures, design, and abstraction. Many topics in this course are mathematically intensive and require a firm understanding of algebraic concepts and experience in problem solving. Students should be comfortable with functions and the concepts found in the uses of functional notation, such as $f(x) = x + 2$ and $f(x) = g(h(x))$. This course builds upon a foundation of mathematical reasoning that should be acquired before attempting this course. Documentation plays a central role in the programming methodology.

TECHNOLOGY & ENGINEERING EDUCATION

1055 TECHNOLOGY/ PRE-ENGINEERING 1 Semester Course 0.5 Credits Grade Level: 9-12

In this course students will explore the nature of technology, technology systems, and the history, evolution, and characteristics of technology as well as its impact on our society, culture, economy, politics, and environment. Topics include: Technology Today & Tomorrow, Communication Engineering & Design, and Energy & Power Engineering & Design. Several hands-on activities in each unit lets students apply the engineering design process to design and make a product.

1056 TECHNOLOGY/PRE-ENGINEERING 2 Semester Course 0.5 Credits Grade Level: 9-12 Prerequisite: Pre-Eng. 1

In this course students will explore the nature of technology, technology systems, and the history, evolution, and characteristics of technology as well as its impact on our society, culture, economy, politics, and environment. Topics include: Construction Engineering & Design, Transportation Engineering & Design, and Bio-Related Engineering & Design. Several hands-on activities in each unit lets students apply the engineering design process to design and make a product.

1060 CADD 1 Year Course 1 Credit Grade Level: 9-12 Prerequisite: Pre-Algebra

Exposes students to "Level 1" CADD skills required for Technical drawings, Graphic communications, and career studies within the engineering field. Topics include: 2D and 3D constructions, dimensioning, intermediate level mathematics, and fundamentals for Technical drawing.

1065 CADD 2 Year Course 1 Credit Grade Level: 10-12 Prerequisite: CADD 1

Intermediate "Level 2" course continues the CADD skills of Technical drawing and introduces the student to engineering drawing. Topics include: Advanced 2D and 3D constructions, 3D solid modeling, rendering.

1067 CADD 3 Year Course 1 Credit Grade Level: 11-12 Prerequisite: CADD 2

Projects relating to the "design" cycle: Design, Documentation, Purchasing, Manufacturing, Assembly, and Final test. *Articulates with Elgin Community College CAD 108*

1070 WOODS TECHNOLOGY 1 Year Course 1 Credit Grade Level: 9-12 Prerequisite: Tech. Pre-Engineering or concurrent

Topics include safety, planning, designing, and building assigned and personal projects. Provides instruction and supervised practice with a variety of tools and machinery.

1075 WOODS TECHNOLOGY 2 Year Course 1 Credit Grade Level: 9-12 Prerequisite: "C" or better in Woods 1

Covers advanced woodworking principles, including furniture design, advanced construction, joint making, spray finishing, drawer, cabinet construction, and the design of blueprints.

1080 BUILDING TRADES Year Course 1 Credit Grade Level: 10-12 Prerequisite: Woods 1

Introduces students to various aspects of residential design and construction techniques through lectures, text reading, and hands-on design and construction of a framed building.

FAMILY & CONSUMER SCIENCE

1085 CHILD GROWTH & DEVELOPMENT Semester Course 0.5 Credits Grade Level: 9-12

Students will gain knowledge and understanding of child development from prenatal through early adolescence stages. We will study and apply physical, social, emotional, and intellectual principles. *Articulates with ECC ECE 174.*

1086 SCHOOL AGE CHILD DEVELOPMENT Semester Course 0.5 Credits Grade Level: 9-12 Prerequisite: Child Growth

Students will gain knowledge and understanding of school age child development from age 4 through early adolescence stages. We will study and apply through observation and hands-on interaction physical, social, emotional, and intellectual principles.

1087 INTERIOR DESIGN Semester Course 0.5 Credits Grade Level: 9-12

Students examine the interrelationship of human needs, culture, and housing. They trace the development of housing from primitive shelter to today's high-tech homes. Students learn about design in housing, floor plans, housing construction, and materials, furniture styles, appliances, and decorating materials. A final project will be prepared and their design presented as if there is a client-designed relationship.

CAREER/TECH ED. CAPSTONE COURSES

1095 CAREER INTERNSHIP

Semester Course **0.5 Credits**
Grade Level: 12

Senior students will learn and practice employability skills, complete career research, maintain daily logs, develop a portfolio, and complete an intern experience outside the building.

9400 COOPERATIVE EDUCATION – CLASSROOM

Year Course **1 Credit**
Grade Level: 12 **Prerequisite: Dept. perm.;**
Must take orientation and
preparation level in area of
interest

The classroom element of Co-op meets daily for 45 minutes. Textbooks, workbooks, lectures, group work, and guest speakers guide students through topics such as careers, banking, basic math, and general job skills. Students must attempt to seek employment in a chosen area of career interest.

9405 COOPERATIVE EDUCATION – ON THE JOB TRAINING

Year Course **2 Credits**
Grade Level: 12 **Prerequisite: Department**
perm.

Students are responsible for securing their own employment in an appropriate (approved) work site. Must work a minimum of 10 hours per week. Must attempt to seek employment in a chosen area of career interest.

INDEPENDENT STUDY

Semester Course **0.5 Credit**
Grade Level: 12 **Prerequisite: Exhausted**
the curriculum

Course conducted with teachers as mentors, enables student to explore CTE related topics of interest. Independent study serves as an opportunity for students to expand their expertise in a particular specialization, to explore a topic in greater detail, or to develop more advanced skills.

HUMANITIES: FINE ARTS/FOREIGN LANGUAGE

COURSE OFFERINGS

MUSIC EDUCATION

2000 INTRODUCTION TO BAND

Semester Course 0.5 Credits
Grade Level: 9-12

For students who wish to learn to play a band instrument. Students must have a band instrument available or be willing to rent one. Students participate in all marching and concert band activities.

2005 BAND

Year Course 1 Credit
Grade Level: 9-12 **Prerequisite: Prior exp. on a band instrument**

Study and perform a wide variety of band literature, including instruction in rhythm, blend, balance, and tone quality. Students participate in all marching and concert band activities. *Course may be repeated.*

2010 JAZZ ENSEMBLE

Year Course 1 Credit
Grade Level: 9-12 **Prerequisite: Instr. Approval**

Study and perform jazz and pop literature, theory, and history. Students participate in all marching and concert band activities. Course may be repeated.

2012 PERCUSSION ENSEMBLE

Semester Course 0.5 Credits
Grade Level: 9-12

Open to all students who are interested in learning about and performing on the vast types of percussion instruments. Students will perform multiple concerts per semester as well as participating in the Marching Band program. Curriculum will include history, development, theory, and technique in a performance-oriented setting.

2015 MUSIC KEYBOARDING 1

Semester Course 0.5 Credits
Grade Level: 9-12 **Prerequisite: No prior exp.**

Introduces students to basic keyboard skills and provides opportunities to experience and understand the keyboard synthesizer. Keyboard synthesizers and headphones will be provided. Any student with prior experience should strongly consider enrolling in Level 2 or 3. Contact instructor if uncertain.

2020 MUSIC KEYBOARDING 2

Semester Course 0.5 Credits
Grade Level: 9-12 **Prerequisite: Music Keyb. 1 or prior experience**

A continuation of Musical Keyboarding. Students will increase their knowledge in chord accompaniments, music rudiments, and various playing styles.

2021 MUSIC KEYBOARDING 3

Semester Course 0.5 Credits
Grade Level: 10-12 **Prerequisite: Instr. Approval**

For the keyboard student who is beyond level 2. Students in this class go much more in depth into standard keyboard literature and will participate in performances.

2023 INTRODUCTION TO CHORUS

Semester Course 0.5 Credits
Grade Level: 9-12

For beginning chorus students to learn basic skills in music theory, aural skills, and musicianship before enrollment in Chorus.

2025 CHORUS

Year Course 1 Credit
Grade Level: 9-12 **Prerequisite: Intro. to Chorus or instructor approval**

Study and perform traditional and contemporary choral literature. Students learn the fundamentals of good singing, music notation, sight reading, breath control, tone production, and listening techniques. *Course may be repeated.*

2030 CHORALE

Year Course 1 Credit
Grade Level: 11-12 **Prerequisite: Prev. chorus exp., audition, and instructor approval**

Study advanced choral literature in a small ensemble setting. Emphasis on performing techniques and music reading skills.

2035 TRADITIONS OF MUSIC

Semester Course 0.5 Credits
Grade Level: 9-12

This is a music survey course which explores the origins of music and the effect of previous musical styles and composers on current popular music.

2036 MUSIC VIDEO PRODUCTION

Semester Course 0.5 Credits
Grade Level: 11-12

Students will create music videos combining appropriate visual and musical sources from various historical periods. Will also develop senior video for graduation. Must have access to a digital video recorder. Preference to seniors.

2037 AMERICAN ROUTES IN MUSIC
Semester Course 0.5 Credits
Grade Level: 9-12 Prerequisite: "C" or better
in Traditions of Music

Students will develop and understand a deeper appreciation of musical forms throughout the 20th Century. Emphasis is on the development of jazz, country, Broadway, rock & roll, and many others.

2038 MUSIC THEORY 1
Semester Course 0.5 Credits
Grade Level: 11-12 Prerequisite: Strong music
background & instr. approv.

For the serious music student. Suggested for any student considering a music major or minor in college. Concentrates on principles of music theory with emphasis on practical knowledge, basic 4-part writing, and aural development.

2039 MUSIC THEORY 2
Semester Course 0.5 Credits
Grade Level: 11-12 Prerequisite: Music Theory
1 or instr. approval

A continuation of Music Theory 1 with more emphasis on ear training, sight-singing, chromatic harmonic analysis, and more complex 4-part writing. Arranging for ensembles and compositional styles and techniques will be done as well.

THEATER EDUCATION

2040 THEATER 1
Semester Course 0.5 Credits
Grade Level: 9-12

Perform individually and in small groups, studying pantomime, improvisation, and basic acting techniques for drama and comedy. The technical aspects of theater history may also be covered.

2045 THEATER 2
Semester Course 0.5 Credits
Grade Level: 9-12 Prerequisite: Theater 1

A continuation of the Theater 1 class. Students will study advanced concepts in acting and production. Emphasis is on memorization and scene preparation.

2046 THEATER 3
Semester Course 0.5 Credits
Grade Level: 11-12 Prerequisite: Theater 1 & 2

A continuation of Theater 2 class. Students will create, stylize, and perform advanced theatrical concepts. Emphasis is on varying theatrical periods and classroom participation.

2047 TECHNICAL THEATER 1
Semester Course 0.5 Credits
Grade Level: 10-12

Introduction to elements of play production, including use of tools, elements of set construction, basic stage lighting, make-up, and costuming.

2048 TECHNICAL THEATER 2
Semester Course 0.5 Credits
Grade Level: 10-12 Prerequisite: Tech. Theater 1

This course will expand knowledge of play production and will introduce elements of design for sets, lights, etc. More opportunity to specialize in one area.

ART EDUCATION

2056 INTRODUCTION TO DRAWING & PAINTING
Year Course 1 Credit
Grade Level: 9-12

Students will visually and manually explore the elements and principles of art and design through drawing and painting media. Students will experiment with various media, including but not limited to the following: Pencil, pen/ink, colored pencil, oil pastel, marker, and acrylic paint. *See Art Refund Policy.*

2061 INTRODUCTION TO SCULPTURE & CERAMICS
Year Course 1 Credit
Grade Level: 9-12

Students will visually and manually explore the elements of art and principles of design through sculpture media. Students will experiment with various media, including but not limited to: Illustration board, paper, newspaper, paper mache, mixed media, recycled media, surface media (paint, tape, etc.), fabric, and clay. *See Art Refund Policy.*

2065 INTERMEDIATE DRAWING
Year Course 1.0 Credits
Grade Level: 10-12 Prerequisite: Intro to Draw/Paint

Students will develop a personal style while exploring the elements of art and principles of design, utilizing various drawing media. Students will study the human form and will create original drawings using various media that are based on formalism, imitationalism and emotionalism. Students will also create a series of six drawings that develop a definitive mark and convey a cohesive concept. Series will be completed in drawing medium of student's choice. *See Art Refund Policy.*

2068 INTERMEDIATE SCULPTURE & CERAMICS
Year Course 1.0 Credits
Grade Level: 9-12 Prerequisite: Intro. to
Sculpture/Ceramics

Students develop a personal style while exploring the elements of art and principles of design, utilizing various sculpting media including clay. Students will develop a series of sculptures conveying a cohesive concept in choice of sculpting media. *See Art Refund Policy.*

2070 PHOTOGRAPHY 1

Year Course 1 Credit
Grade Level: 9-12

Students will explore the elements and principles of design, lighting techniques, motion experimentation, angle compositions, and color theory through the use of photography. Semester one will include basic darkroom and camera techniques and digital photography. Students must provide their own manual 35mm SLR camera with manual aperture and shutter settings. Students must also purchase their own photo paper. *See Art Refund Policy.*

2075 PHOTOGRAPHY 2

Year Course 1 Credit
Grade Level: 10-12 Prerequisite: "B" or better in Photo 1 or instr. approval

Students will explore photography by experimentation of medium and technique. Students will compose a series of photographs, conveying a cohesive concept. Students must provide their own manual 35mm SLR camera with manual aperture and shutter settings. Students must also purchase their own photo paper. *See Art Refund Policy.*

2085 INTERMEDIATE PAINTING

Year Course 1.0 Credits
Grade Level: 10-12 Prerequisite: Intro. to Drawing/Painting

Students will develop a personal style while exploring the elements of art and principles of design, utilizing various painting media on 2-dimensional surfaces. Acrylic, watercolor and oil mediums will be explored. Students will create a series of original paintings that convey a cohesive concept in choice of paint media, while developing a definitive mark. *See Art Refund Policy.*

2100 DIGITAL PHOTOGRAPHY/GRAPHIC DESIGN

Year Course 1.0 Credits
Grade Level: 10-12 Prerequisite: Photography 1

Students will visually explore the elements and principles of art and design through Photoshop and other mixed media, for the purpose of mass production. Projects may include, but are not limited to, advertising, illustration, fashion design, and interior design. *See Art Refund Policy.*

2205 ADVANCED PLACEMENT (AP) STUDIO ART 2-D DESIGN*

Year Course 1 Credit
Grade Level: 12 Prerequisite: Photo 1 & 2 w/A or B in both; summer work; portfolio review in January; instructor approval.

This class is designed for highly motivated students to do college-level work. A portfolio of about 30 pieces will be submitted in April. The photography pieces should demonstrate your understanding of design principles as applied to photography. The student will have to provide some materials including film. *See Art Refund Policy.*

2210 ADVANCED PLACEMENT (AP) STUDIO ART DRAWING*

Year Course 1 Credit
Grade Level: 12 Prerequisite: 2 yrs. 2D-Art work, A or B in both; summer work; portfolio rev. Jan.; instr. approval.

Students will compile a series of works that explore a drawing / painting concept, synthesizing the elements & principles of art and design as they relate to drawing and / or painting. Students will compile and submit a portfolio that contains actual works and slides of the work created throughout the course. Students will create original, outstanding exemplary works of art, while developing a definitive style and mark. *See Art Refund Policy.*

2215 ADVANCED PLACEMENT (AP) STUDIO ART 3-D DESIGN*

Year Course 1 Credit
Grade Level: 12 Prerequisite: 2 yrs. 3D-Art work, A or B in both; summer work; portfolio rev. Jan.; instr. approval.

Students will compile a series of works that explore a sculptural concept, synthesizing the elements & principles of art and design as they relate to sculpture. Students will create original exemplary works of art. Students will compile a portfolio that contains slides of the work created throughout the course, while developing a definitive style and mark. *See Art Refund Policy.*

FOREIGN LANGUAGE**3000 SPANISH 1**

Year Course 1 Credit
Grade Level: 9-12

Includes listening comprehension, communication, and vocabulary skills. Grammar and conjugation skills are applied to short compositions. Readings reinforce grammar and reading comprehension skills.

3005 SPANISH 2

Year Course 1 Credit
Grade Level: 9-12 Prerequisite: "C" or better in Spanish 1 or instr. approval

Fosters continued cultural awareness, expansion of vocabulary, more complex composition skills, expands grammar and verb conjugation skills. The development of verbal proficiency is continued.

*Indicates weighted grades in this course.

3010 SPANISH 3

Year Course

Grade Level: 10-12

1 Credit

Prerequisite: "C" or better
in Spanish 2 or instr.
approval

Conversation skills are maintained while existing reading and writing skills with the use of advanced grammar. A grammatical review is an integral part of the course.

3015 SPANISH 4

Year Course

Grade Level: 11-12

1 Credit

Prerequisite: "C" or better
in Spanish 3 or instr.
approval.

Course is conducted almost entirely in Spanish. Literature is studied in the context of the cultural and political events of its time. Current events and Spanish and Mexican artists are discussed.

3022 ADVANCED PLACEMENT (AP) SPANISH LANGUAGE & CULTURE*

Year Course

Grade Level: 11-12

1 Credit

Prerequisite: "B" or better in
Spanish 3/4 or instr.
approval

Challenging preparation for possible advanced placement in college foreign language study.

3025 GERMAN 1

Year Course

Grade Level: 9-12

1 Credit

Begin to understand, speak, read, and write German. Emphasis is on building confidence and competence in communicating basic expressions, thoughts, and ideas in German.

3030 GERMAN 2

Year Course

Grade Level: 9-12

1 Credit

Prerequisite: "C" or better in
German 1 or instr. approval

Continues to develop students' abilities to use and comprehend German through meaningful practice in and exposure to spoken and written language. Vocabulary and grammar will increase.

3035 GERMAN 3

Year Course

Grade Level: 10-12

1 Credit

Prerequisite: "C" or better in
German 2 or instr. approval

Improve communication skills, comprehension of German through meaningful practice in and exposure to spoken and written language. Vocabulary and grammar will increase.

3040 GERMAN 4

Year Course

Grade Level: 11-12

1 Credit

Prerequisite: "C" or better in
German 3 or instr. approval.

Communication and comprehension skills are reviewed, reinforced, and improved. Students develop confidence in speaking, writing, and understanding German.

3047 ADVANCED PLACEMENT (AP) GERMAN LANGUAGE & CULTURE*

Year Course

Grade Level: 11-12

1 Credit

Prerequisite: "B" or
better in German 3/4 or
instr. approval

Challenging preparation for possible advanced placement in college foreign language study.

*Indicates weighted grades in this course.

ENGLISH

COURSE OFFERINGS

4000 FRESHMAN ENGLISH

Year Course 1 Credit
Grade Level: 9

Students study various styles of composition and paragraph formation, elements of grammar, writing mechanics, and vocabulary. Students are required to read short stories, novels, and nonfiction.

4005 FRESHMAN ENGLISH DOUBLE BLOCK

Year Course 2 Credits
Grade Level: 9 Prerequisite: Please see Page 4

Designed to be taken by students who need additional improvement in reading and writing skills. Students are required to read short stories, novels, and nonfiction. Designed to help students succeed in all academic areas.

4010 READING FOR SUCCESS DOUBLE BLOCK

Year Course 2 Credits
Grade Level: 9-12 Prerequisite: Test scores & recommendation

A year-long reading intervention course designed to help the struggling reader learn the necessary skills and strategies to read at a proficient level. Emphasis will focus on reading fluency and comprehension of fiction and non-fiction text. Student achievement data and teacher recommendation will determine placement in this course. Will serve as credit for Freshman English.

4012 HONORS FRESHMAN ENGLISH*

Year Course 1 Credit
Grade Level: 9 Prerequisite: Please see Page 4

This class, designed for students entering the Honors English program at Central High School, is a survey course in which literature, vocabulary, composition, research and speech are studied. Through genre-based units, students study poetry, fiction, non fiction, drama and legends. Units of study require in depth analysis, evaluation and critical thinking. Students also study various novels and plays, as well as outside readings and reports. Vocabulary is an integral part of study. Students write numerous essays and are also required to complete a research project.

4020 AMERICAN LITERATURE

Year Course 1 Credit
Grade Level: 10 Prerequisite: English 1 & Teacher Recommendation

Students will focus on themes such as the American Dream and will survey many authors, genres, and styles. Writing is also required. Placement will be determined by teacher recommendation.

4022 HONORS AMERICAN LITERATURE*

Year Course 1 Credit
Grade Level: 10 Prerequisite: Honors Placement

This course covers the literature written in the United States from the Colonial Period to the present. A focus is placed on the content, background, and authors of a wide variety of prose and poetry. Students will study the literary periods and the historical development of American literature. Students will write extensively, including literary analysis and reading responses. In addition, students will create original projects and speak informatively.

4025 AMERICAN LITERATURE STUDIES

Year Course 1 Credit
Grade Level: 10 Prerequisite: English 1 & Teacher Recommendation

Students will focus on themes such as the American Dream and will survey many authors, genres, and styles. Writing is also required. Placement will be determined by teacher recommendation.

4037 WORLD LITERATURE

Semester Course 0.5 Credits
Grade Level: 11-12 Prerequisite: American Literature

This course is a survey of World Literature from the first civilizations to the present day. Study will be through an anthology and the reading of at least one novel. All selections are organized geographically into seven sections – The Mediterranean, Continental Europe, Africa, the Far East, Latin America, North America, and Great Britain – and each section contains a wide array of works from that region of the world. Students will examine various aspects including style, techniques, and themes of each era. All genres are included. Students will also be expected to analyze literature as well as respond to it. Essays, critical analyses, and personal response papers will be required.

*Indicates weighted grades in this course.

4038 CONTEMPORARY LITERATURE
Semester Course **0.5 Credits**
Grade Level: 11-12 **Prerequisite: American Literature**

This course is a survey of post-modern literature with an emphasis on discussion. Focuses on the global and multicultural nature of contemporary society through various styles and genres: poems, essays, short stories, plays, and novels.

4040 ADVANCED PLACEMENT (AP) ENGLISH LITERATURE & COMPOSITION*

Year Course **1 Credit**
Grade Level: 11 **Prerequisite: Honors American Lit.**

Combines English Literature and expository writing. Emphasis is on analysis and interpretation of individual literary works. Stresses the process of writing essays. This course is required for AP English Language & Composition.

4044 BRITISH LITERATURE
Semester Course **0.5 Credits**
Grade Level: 11-12 **Prerequisite: American Lit.**

The study of British Literature from *Beowulf* through modern literature and will include Medieval, Renaissance, and the Romantic periods while studying authors such as Shakespeare, Chaucer, and Stevenson.

4045 COLLEGE PREP ENGLISH
Year Course **1 Credit**
Grade Level: 12 **Prerequisite: "C" or better in both Adv. Comp. and British Literature**

Includes practicing techniques of critical reading, writing, and thinking. Mythology and other college level readings are studied. Vocabulary building and at least two research papers required.

4050 ADVANCED PLACEMENT (AP) ENGLISH LANGUAGE & COMPOSITION*
Year Course **1 Credit**
Grade Level: 12 **Prerequisite: "B" in Eng. Lit. and "B" in American Lit.**

Students will engage in intensive study of literary works from mythology to philosophy, novels to short stories, and drama. Writing assignments will stress critical analysis and interpretation.

4055 SPEECH COMMUNICATION 1
Semester Course **0.5 Credits**
Grade Level: 10-12 **Prerequisite: English 1**

Covers the principles of communication. Speeches that inform, persuade, inspire, and convince are required, culminating in a polished speech that reflects good communication skills.

4060 SPEECH COMMUNICATION 2
Semester Course **0.5 Credits**
Grade Level: 10-12 **Prerequisite: Speech 1**

Students will develop more skills in persuasive speaking, inspirational speaking, and forms of debate. Introductions of oral interpretation and more work in small group communication are included.

4065 JOURNALISM 1
Year Course **1 Credit**
Grade Level: 10-12 **Prerequisite: "C" or better in English 1**

Students learn journalistic jargon, write news stories, including sports, editorials, features, columns, and reviews. Interviewing skills are stressed and the school newspaper is published.

4070 JOURNALISM 2
Year Course **1 Credit**
Grade Level: 11-12 **Prerequisite: Journalism 1**

Students write extensively in the basic news media forms – straight news, sports, features, editorials, and columns. Specific skills may be developed in video and radio broadcasting, including script writing.

4080 ADVANCED COMPOSITION
Semester Course **0.5 Credits**
Grade Level: 11-12 **Prerequisite: American Literature**

Instruction and practice in the many types of writing, i.e. narrative, argumentative, research-based, descriptive, literary criticism, etc. Some reading will be required.

4085 WRITING FOR COLLEGE & CAREERS
Semester Course **0.5 Credits**
Grade Level: 11-12 **Prerequisite: American Literature**

This semester-long writing class focuses on the transition from high school to post-secondary options and the working world. The class is divided into four major units of study: self-discovery (goal setting and personality types), post-secondary options (college, job training, employment), the working world (career research), and technical writing for the workplace (resumes, cover letters, memos, etc).

4090 WRITER'S CRAFT
Semester Course **0.5 Credits**
Grade Level: 11-12

Recommended for students who struggle in writing. Focuses on the fundamentals of writing, including grammar, mechanics, and spelling as well as the different types of writing. May not be taken in conjunction with Advanced Composition.

*Indicates weighted grades in this course.

4095 CREATIVE WRITING

Semester Course **0.5 Credits**
Grade Level: 11-12

This course explores writing as an art. Students will read and analyze poetry, short stories, essays and excerpts, and create works of fiction, poetry, and drama. Students will critique their own work and that of their classmates. Throughout the semester students will compile a portfolio of revised work.

4100 WOMEN IN LITERATURE

Semester Course **0.5 Credits**
Grade Level: 11-12

This course is dedicated to the study of literature written by women. The course will include fiction, non-fiction, and poetry. Reading, writing, and class participation is expected.

4105 SCIENCE FICTION/FANTASY LITERATURE

Semester Course **0.5 Credits**
Grade Level: 11-12 **Prerequisite: American Lit.**

This class will explore the genres of science fiction and fantasy fiction. Readings will include short stories and novels. Critical thinking skills, reading, writing, and class participation are required.

4110 BIBLE AS LITERATURE

Semester Course **0.5 Credits**
Grade Level: 11-12

This course is designed to examine how Biblical histories, parables, events and figures have influenced the development of Western and world literature. Just as Greek and Roman histories, mythologies, and philosophies have had a transforming effect upon the themes, conflicts, characters, symbols, images, and language employed in Western literature, so too has the Bible.

This course is not a historical survey of the Bible, nor is it an examination of the theological validity of the Bible as a sacred text. However, because the Bible is recognized as a sacred text for people of many faiths, every attempt to present Biblical material with respect and tolerance for differences will be maintained as a priority for all class instruction, interaction, and assignments. The text for this course is not the Bible, but rather an anthology which includes some actual Biblical passages as well as other works of literature based on the Bible.

4120 HIGH SCHOOL READING STRATEGIES

Semester Course **0.5 Credits**
Grade Level: 10-12 **Prerequisite: Instructor recommendation only**

Class designed for those struggling with reading fluency and comprehension. Project CRISS strategies, fiction, and nonfiction reading techniques covered.

4121 COLLEGE READING STRATEGIES

Semester Course **0.5 Credits**
Grade Level: 11-12 **Prerequisite: Instructor recommendation only**

Class designed for students who need work on higher level reading skills for college, the ACT, or the work environment. Comprehension, speed, and fluency will be addressed.

HONORS/AP ENGLISH SUGGESTED COURSE FLOW

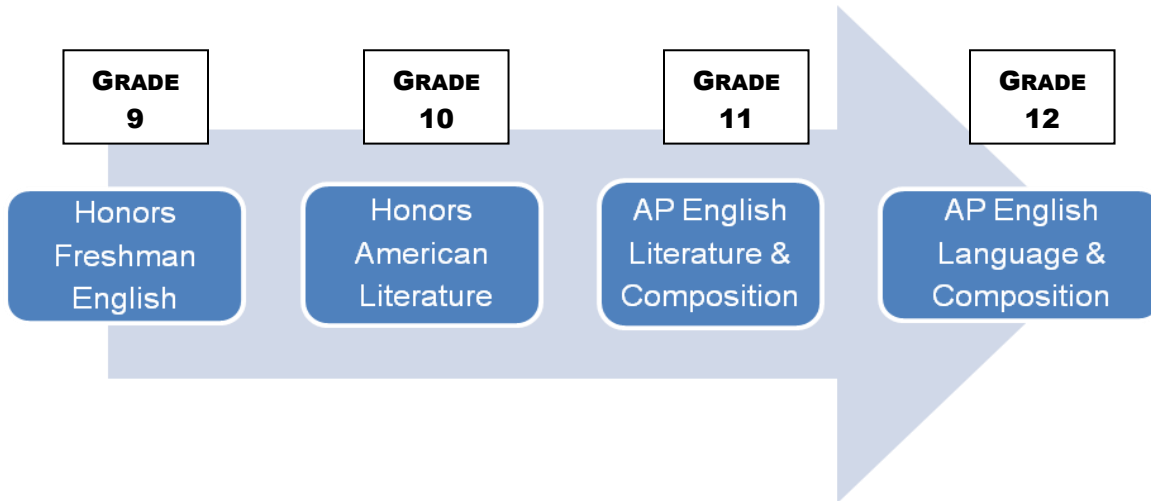

COLLEGE PREPARATORY ENGLISH SUGGESTED COURSE FLOW

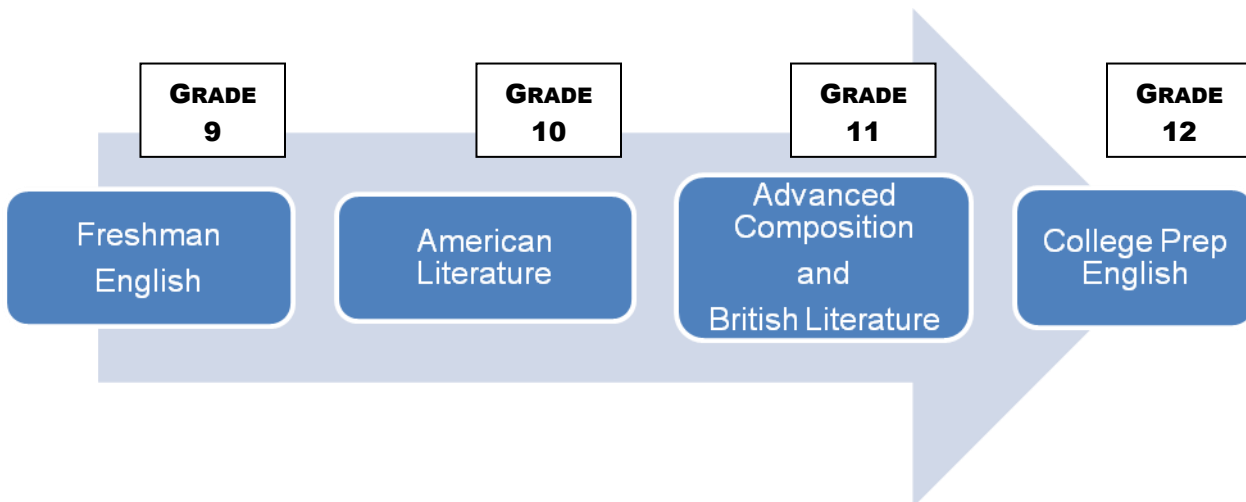

COMMUNITY COLLEGE/TRADE-TECH SCHOOL ENGLISH SUGGESTED COURSE FLOW

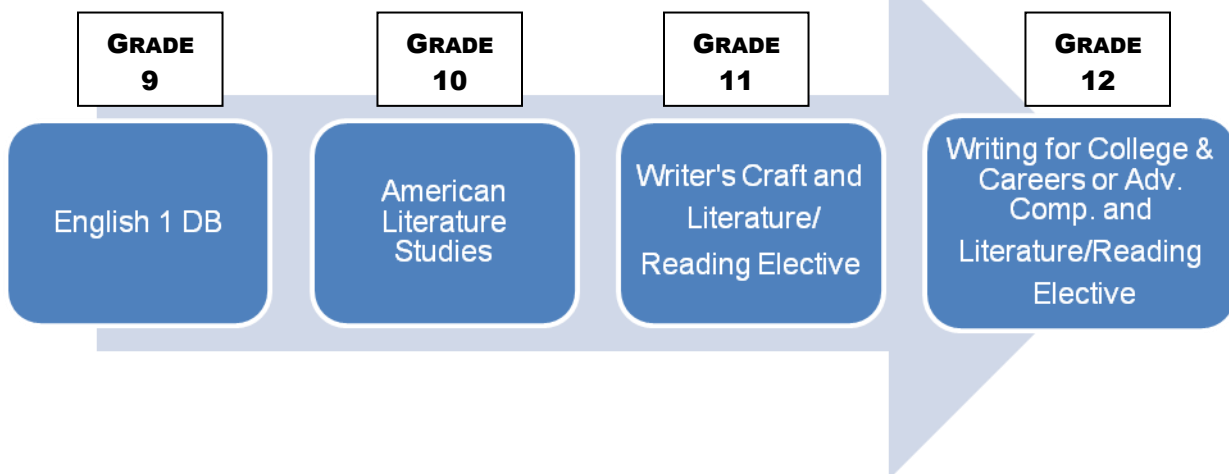

Literature/Reading Elective Options: British Literature, Contemporary Literature, High School Reading Strategies, Science Fiction/Fantasy Literature, or World Literature.

Other Elective Options: Creative Writing, Journalism 1, Journalism 2, Speech.

MATHEMATICS

COURSE OFFERINGS

5015 GENERAL PRE-ALGEBRA

Year Course **1 Credit**
Grade Level: 9-11 **Prerequisite: Teacher rec, only**

This year-long mathematics class will begin the study of basic Algebraic and Geometric concepts.

5020 GENERAL ALGEBRA

1 Year Course **1 Credit**
Grade Level: 10-12 **Prerequisite: General Pre-Alg. or teacher rec.**

This Algebra One class is designed to teach algebraic skills for problem solving. Students learn to solve first and second degree equations and to develop equations from real world applications.

5022 INFORMAL GEOMETRY

1 Year Course **1 Credit**
Grade Level: 10-12 **Prerequisite: General Alg.**

This Geometry class is designed to teach geometric skills for problem solving. Students learn about triangles, parallel lines, circles, areas of polygons, and the Pythagorean theorem to develop real world applications.

5025 PRE-ALGEBRA

Year Course **1 Credit**
Grade Level: 9-11

A comprehensive course designed to help students make the transition from elementary mathematics into the field of Algebra. The emphasis is on the beginning of Algebraic and Geometric concepts and problem solving strategies.

5030 ALGEBRA 1

Year Course **1 Credit**
Grade Level: 9-12 **Prerequisite: Pre-Algebra or teacher consent**

Designed to teach algebraic skills for problem-solving. Students learn to solve first and second degree equations and to develop equations from problems.

5035 ALGEBRA 1 DOUBLE BLOCK

Year Course **2 Credits**
Grade Level: 9-12 **Prerequisite: Pre-Algebra or teacher consent**

Algebra 1 Double Block teaches the same skills as Algebra 1 but meets daily and yields two credits.

5040 ALGEBRA 2

Year Course **1 Credit**
Grade Level: 9-12 **Prerequisite: Algebra 1**

An extension of Algebra 1 with study in quadratics, systems of linear equations, and complex numbers.

5045 ALGEBRA 2 DOUBLE BLOCK

Year Course **2 Credits**
Grade Level: 9-12 **Prerequisite: Algebra 1**

An extension of Algebra 1 with study in quadratics, systems of linear equations, logarithmic and exponential equations, complex numbers, conics, and zeroes of polynomials. Meets daily and yields two credits.

5052 ACCELERATED ALGEBRA 2

Year Course **1 Credit**
Grade Level: 9-12 **Prerequisite: B in Algebra 1 and instructor conf.**

The concepts studied are the same as Algebra 2 and College Algebra demanding more critical thinking.

5055 GEOMETRY

Year Course **1 Credit**
Grade Level: 9-12 **Prerequisite: Algebra 1**

Material includes triangles, parallel lines, circles, and associated lines, various loci, inequalities of lines and angles, areas of polygons, the Pythagorean theorem, and square roots.

5060 GEOMETRY DOUBLE BLOCK

Year Course **2 Credits**
Grade Level: 9-12 **Prerequisite: Algebra 1**

Geometry Double Block teaches the same skills as Geometry but meets daily and yields two credits.

5067 ACCELERATED GEOMETRY

Year Course **1 Credit**
Grade Level: 9-10 **Prerequisite: Algebra 1 with B or better**

Covers the same topics as in Geometry demanding more critical thinking skills. Course content is enhanced with supplemental topics.

5070 TRIGONOMETRY

Semester Course **0.5 Credits**
Grade Level: 10-12 **Prerequisite: Geometry and Algebra 2 DB w/C or better in Algebra 2 DB.**

Covers the concepts of trigonometry and the relationships which exist in a right triangle. Content includes trigonometric functions, identities, and applications to oblique triangles.

5075 HONORS PRE-CALCULUS*

Year Course 1 Credit
Grade Level: 10-12 Prerequisite: A In Accelerated Algebra 2

Concepts taught include the following: polynomial, rational, exponential, logarithmic, and trigonometric functions, Sequences, series, probability, Linear algebra, analytic Geometry, Limits and an introduction to Calculus. This course is designed to prepare students for the rigor of AP Calculus BC. Can be taken concurrently with first semester Trigonometry.

5077 PRE-CALCULUS

Year Course 1 Credit
Grade Level: 10-12 Prerequisite: B in Trigonometry & Acc. Algebra 2 or College Alg.

Polynomial, rational, exponential, logarithmic, and trigonometric functions and their graphs. Sequences, series, probability, and linear algebra. Can be taken concurrently with first semester trigonometry.

5080 COLLEGE ALGEBRA

Semester Course 0.5 Credits
Grade Level: 10-12 Prerequisite: Geometry and Algebra 2 DB w/C or better in Algebra 2 DB

Algebraic skills will be sharpened with an extension of the difficulty of their application.

5085 PROBABILITY & STATISTICS

Semester Course 0.5 Credits
Grade Level: 11-12 Prerequisite: Algebra 2

This is an introductory statistics course. Topics covered include exploring data, numerical summaries, graphical summaries, correlation, association, linear regression, data collection, experimental design and formal probability.

5090 TRANSITION TO COLLEGE MATH

Semester Course 0.5 Credits
Grade Level: 11-12 Prerequisite: Algebra 2

Designed for the trade school, junior college, or college-bound student in non-technical career areas. Provides background in graphing, statistics, and other non-technical math areas.

5097 CALCULUS

Year Course 1 Credit
Grade Level: 11-12 Prerequisite: Pre-Calculus

Limits, derivatives, definite, and indefinite integrals and their applications will be covered.

5100 ADVANCED PLACEMENT (AP) CALCULUS AB*

Year Course 1 Credit
Grade Level: 11-12 Prerequisite: 85% In Pre-Calculus

Concepts taught include limits and continuity, derivatives and their applications, and integrals and their applications. Material to be covered will be dictated by the requirements of the College Board.

5105 ADVANCED PLACEMENT (AP) STATISTICS*

Year Course 1 Credit
Grade Level: 11-12 Prerequisite: B or better in College Algebra or Accelerated Algebra 2

Introduction to the major concepts and tools for collecting, analyzing, drawing conclusions, and using statistical inference. Material to be covered will be dictated by the requirements of the College Board.

5110 ADVANCED PLACEMENT (AP) CALCULUS BC*

Year Course 1 Credit
Grade Level: 11-12 Prerequisite: 90% in Pre-Calculus and Instr. approval

The same concepts taught in AP Calculus AB with the addition of L'Hospital's Rule, improper integrals, and partial fractions. Parametric, vector, and polar functions, infinite series, which include geometric, power, and Taylor's Series. Material to be covered will be dictated by the requirements of the College Board.

4125/5044 READING & MATH STRATEGIES

Semester Course 0.5 Credits
Grade Level: 11 Prerequisite: Recommend. only

Semester course designed for those students who are not meeting the Illinois State Learning Standards for 11th graders. Nine weeks will be devoted to reading strategies and nine weeks will be devoted to math application skills. This course will sharpen reading and math skills necessary for successful participation in high school courses and tests requiring reading comprehension and mathematical application. Student achievement data and teacher recommendation will determine placement in this course. This course does NOT earn a student credit in English or Math. Credit earned will be applied to student's general elective requirements.

*Indicates weighted grades in this course.

ACCELERATED MATH SUGGESTED COURSE FLOW

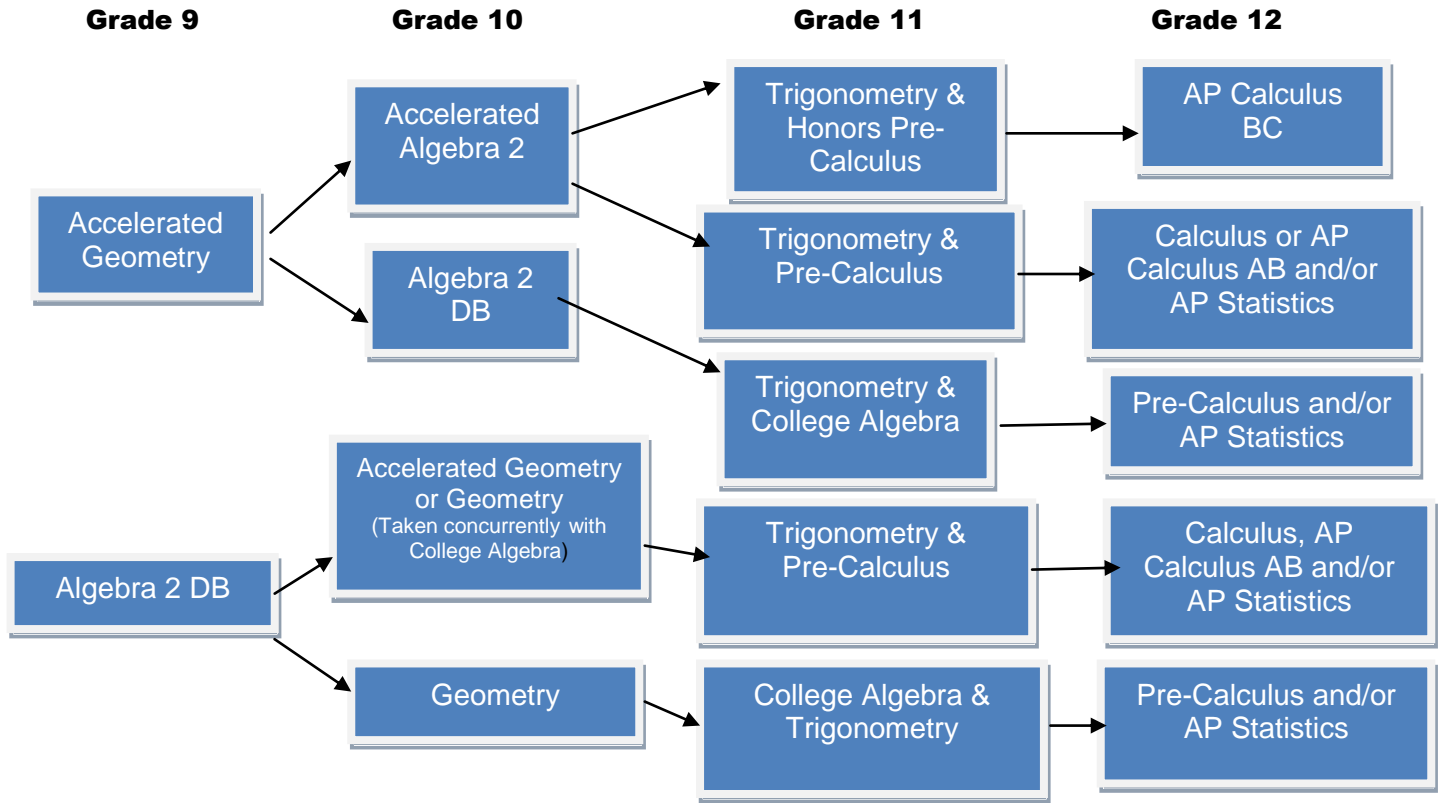

COLLEGE PREPARATORY MATH SUGGESTED COURSE FLOW

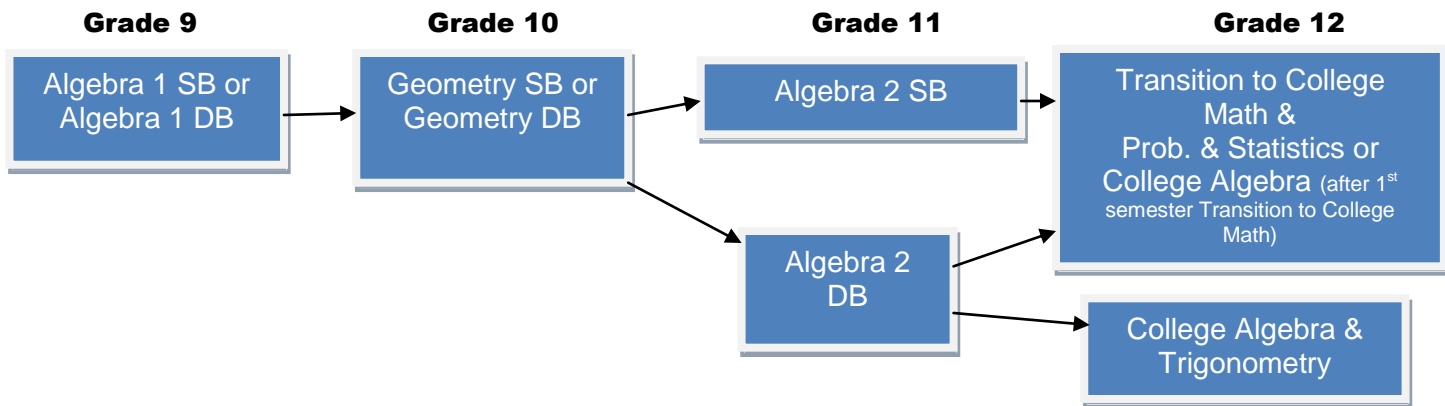

COMMUNITY COLLEGE/TRADE-TECH SCHOOL SUGGESTED COURSE FLOW

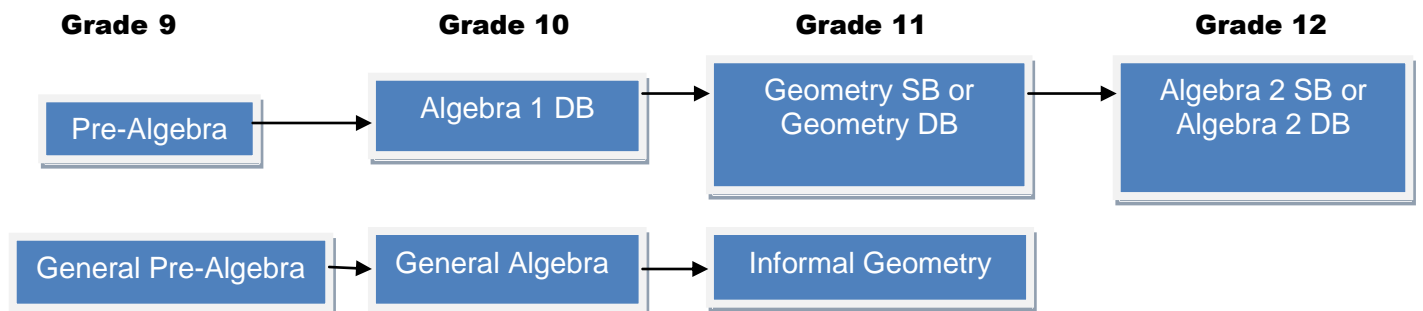

PHYSICAL EDUCATION/HEALTH/DRIVERS EDUCATION

COURSE OFFERINGS

6010 PHYSICAL EDUCATION 1 BOYS
Semester Course 0.5 Credits
Grade Level: 9

Consists of units on fitness training as well as selected units on skill development in a variety of game and recreational activities.

6015 PHYSICAL EDUCATION 1 GIRLS
Semester Course 0.5 Credits
Grade Level: 9

Consists of units on fitness training as well as selected units on skill development in a variety of game and recreational activities.

6020 PHYSICAL EDUCATION 2 BOYS
Semester Course 0.5 Credits
Grade Level: 10

Consists of units on fitness training as well as selected units on skill development in a variety of game and recreational activities.

6025 PHYSICAL EDUCATION 2 GIRLS
Semester Course 0.5 Credits
Grade Level: 10

Consists of units on fitness training as well as selected units on skill development in a variety of game and recreational activities.

6030 PHYSICAL EDUCATION 3 BOYS
Semester Course 0.5 Credits
Grade Level: 11

Consists of units on fitness training as well as selected units on skill development in a variety of game and recreational activities.

6035 PHYSICAL EDUCATION 3 GIRLS
Semester Course 0.5 Credits
Grade Level: 11

Consists of units on fitness training as well as selected units on skill development in a variety of game and recreational activities.

6040 PHYSICAL EDUCATION 4 BOYS
Semester Course 0.5 Credits
Grade Level: 12

Consists of units on fitness training as well as selected units on skill development in a variety of game and recreational activities.

6045 PHYSICAL EDUCATION 4 GIRLS
Semester Course 0.5 Credits
Grade Level: 12

Consists of units on fitness training as well as selected units on skill development in a variety of game and recreational activities.

6050 DRIVERS EDUCATION
Semester Course 0.5 Credits
Grade Level: 9-12
Prerequisite: 2.0 GPA (cum. or prev. sem.) & 15 yrs. old within 3 months of 1st day of class.

Prepares students to take the Illinois State Driver's Exam. Units include automobiles, maintenance, effects of alcohol and drugs on driver's reactions, city, highway, and expressway driving, Rules of the Road, safety, and maneuvers.

6060 HEALTH 1 (GRADUATION REQ.)
Semester Course 0.5 Credits
Grade Level: 9

Covers attitudes and practices related to healthy living. Units include self-image, relationships, human anatomy including reproduction, AIDS and other communicable diseases and community health. Taken in lieu of one semester of P.E. in the freshman year.

6066 HEALTH 2 (GRADUATION REQ.)
Quarter Course 0.25 Credits
Grade Level: 11-12 Prerequisite: Health 1

This is a continuation of Health 1 and is a graduation requirement.

6067 FIRST AID (GRADUATION REQ.)
Quarter Course 0.25 Credits
Grade Level: 11-12 Prerequisite: Health 1

Covers wound care, splinting, and other aspects of patient care. Additionally, all students will be CPR, first aid, and AED certified upon completion of this class.

6070 WALKING & WELLNESS
Semester Course 0.5 Credits
Grade Level: 9-12

This is an outside walking program that will be outside unless there is lightning or the wind chill is below 0 with a variety of alternative activities being completed during inclement weather. Students will keep a daily log of required walking & wellness information and will complete a semester project. Each student will need proper attire for weather conditions.

6080 RESISTANCE TRAINING**Semester Course**
Grade Level: 9-12**0.5 Credits**
Prerequisite: "B" or higher
in all PE classes or instr.
approval.

Students will be working with instructor-prescribed resistance programs. An emphasis will be placed on strength training with regards to training, resistance, repetitions, safety, spotting techniques, and general target muscles.

6082 INTENSIVE PERSONAL TRAINING**Semester Course**
Grade Level: 10-12**0.5 Credits**
Prerequisite: 2 semesters
of Resistance Training

This class will target students wishing to get a more intense, personalized workout. Student-athletes will complete a workout provided by their coach or trainer. Non-athletes create a personalized, instructor-approved program.

6100 TEAM & INDIVIDUAL SPORT OFFICIATING**Semester Course**
Grade Level: 11-12**0.5 Credits**

This class is designed to allow students to become an IHSA certified official in Illinois. Each student must be 17 yrs. old or turn 17 during the semester to become certified. Students must become certified in at least two sports, per semester. This will be both a classroom and practical experience. Students have the opportunity to become certified in football and volleyball during the first semester and basketball, softball, and baseball during the second semester. Possible additional sports to be added are: soccer and wrestling. Students are required to purchase their own Fox 40 whistle and official's shirt. Students also need black athletic shorts or sweats. Lab fee will be between \$40 and \$80 for certification expenses. Students will obtain P.E. credit.

SCIENCE

COURSE OFFERINGS

7000 INTRODUCTION TO PHYSICAL SCIENCE (GRADUATION REQ.)

Year Course 1 Credit
Grade Level: 9

Covers the physical sciences and how scientific knowledge is acquired. This course provides a foundation for the study of advanced physical sciences. A variety of laboratory investigations are included.

7005 EARTH SCIENCE (GRADUATION REQ.)

Semester Course 0.5 Credits
Grade Level: 9-10

Topics include the changing earth, earth materials, mapping, the earth's history, geologic time, meteorology, groundwater, the atmosphere, erosion, pollution, and mankind's effects on the environment.

7010 EARTH SCIENCE 2

Semester Course 0.5 Credits
Grade Level: 10-12 **Prerequisite:** "C" or better
In Earth Science

Students will use their previous knowledge from Earth Science and other science classes to study climatic patterns, meteorology, groundwater, the atmosphere, erosion, pollution, and mankind's effects on the environment.

7015 ASTRONOMY

Semester Course 0.5 Credits
Grade Level: 10-12 **Prerequisite:** "C" or better
in Earth Sci. & Algebra 1

Topics include the history of astronomy, the nature of light, telescopes, the solar system, stellar evolution, origin of the universe, and space exploration. Students will need to make some night observations.

7020 CURRENT SCIENCE TOPICS

Semester Course 0.5 Credits
Grade Level: 10-12 **Prerequisite:** One sem. of
Biology or Applied Biology

Students will read and discuss current technology, research, and topics in science today.

7023 ACCELERATED BIOLOGY

Year Course 1 Credit
Grade Level: 9 **Prerequisite:** Please see
Page 4

A course similar to Biology with areas of study more thoroughly investigated. Includes study of biochemistry and microbiology. Greater emphasis placed on critical thinking and problem solving.

7025 BIOLOGY (GRADUATION REQ.)

Year Course 1 Credit
Grade Level: 10-12

A study of living things. Principles of experimental design, cytology, genetics, botany, evolution, and ecology will be studied.

7030 APPLIED BIOLOGY

Year Course 1 Credit
Grade Level: 10-12 **Prerequisite:** Instr. recomm.

Applied Biology is a relevant study of the living world around us. Students study and survey the complexity of living organisms and explore the interdependence of diverse life forms on Earth. During the first semester of study, students build a solid foundation of Taxonomy, Ecology, and Evolution. The following semester explores the chemical make-up of individual organisms through the study of their DNA and genetics, concluding with a study of organ systems and dissection of representative invertebrates and vertebrates. This class builds on the skills gained throughout the year to provide a comprehensive view of many topics relevant to biological study today.

7032 ADVANCED PLACEMENT (AP) BIOLOGY*

Year Course 1.25 Credits
Grade Level: 11-12 **Prerequisite:** "B" in both
sems. of Biology & Chemistry

Equivalent to an introductory freshman level college biology class. Emphasis is placed on lab skills, critical thinking, logic, and the problem solving skills needed to pass the AP exam. Must maintain C or better in first semester.

7045 CHEMISTRY

Year Course 1 Credit
Grade Level: 10-12 **Prerequisite:** "C" or better in both
sems. of Biology & Algebra 1

Topics include structure and interactions of matter, stoichiometry, states of matter, chemical equilibrium, acids, and bases.

7047 ACCELERATED CHEMISTRY

Year Course 1 Credit
Grade Level: 10-12 **Prerequisite:** "B" or better in both
sems. of Biology & Algebra 1

Same concepts as general chemistry but at a faster pace and more in-depth discussion of topics.

*Indicates weighted grades in this course.

7050 ADVANCED PLACEMENT (AP) CHEMISTRY***Year Course** 1.25 Credits**Grade Level: 11-12** Prerequisite: "B" or better both sems. of Accel. Chem. or "A" or better both sems. of Chemistry w/necessary lab work to be done prior to start of class.

Equivalent to an introductory freshman level college chemistry class. Emphasis is placed on lab skills, critical thinking, logic, and problem solving skills needed to pass the AP exam. Must maintain C or better first semester.

7060 PHYSICS**Year Course** 1 Credit**Grade Level: 11-12** Prerequisite: "C" or better in Algebra 2

A study of the relationship between matter and energy. Topics include the study of motion, heat, electricity, and magnetism, optics, sounds, and modern topics such as special relativity and high energy physics.

7065 ADVANCED PLACEMENT (AP) PHYSICS B***Year Course** 1.25 Credits**Grade Level: 11-12** Prerequisite: "B" or better in Pre-Calc. or Physics, mandatory instructor mtg.

Equivalent to an introductory freshman level college physics class. Emphasis is placed on lab skills, critical thinking, logic, and problem solving skills needed to pass the AP exam. Must maintain C or better first semester.

Note: All Agriculture classes (Courses 1200, 1205, 1206, 1210, 1211, 1215, and 1216) may also be taken for Science credit. Please see course descriptions in the Career/Tech Education section for specific information on these courses).

*Indicates weighted grades in this course.

ACCELERATED/AP SCIENCE SUGGESTED COURSE FLOW

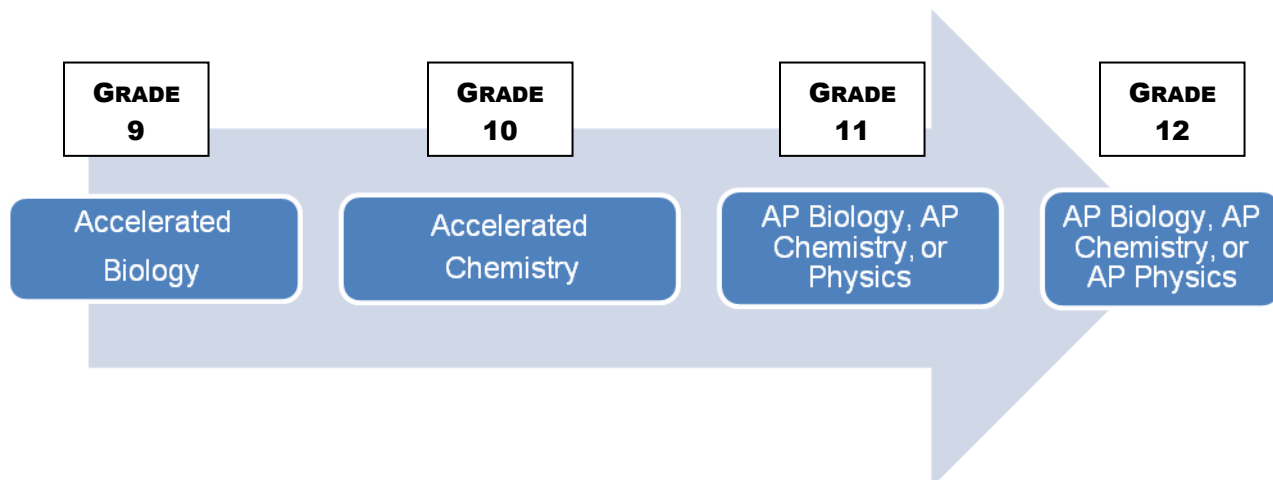

Note: ALL students MUST also complete the one semester course Earth Science during freshman or sophomore year.

COLLEGE PREPARATORY SCIENCE SUGGESTED COURSE FLOW

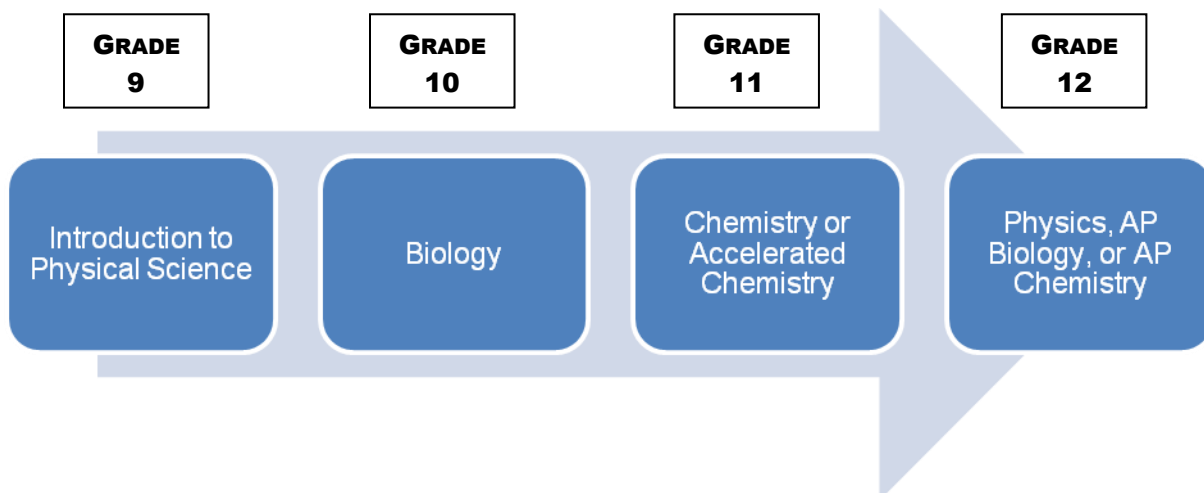

Note: ALL students MUST also complete the one semester course Earth Science during freshman or sophomore year.

COMMUNITY COLLEGE/TRADE-TECH SCHOOL SCIENCE SUGGESTED COURSE FLOW

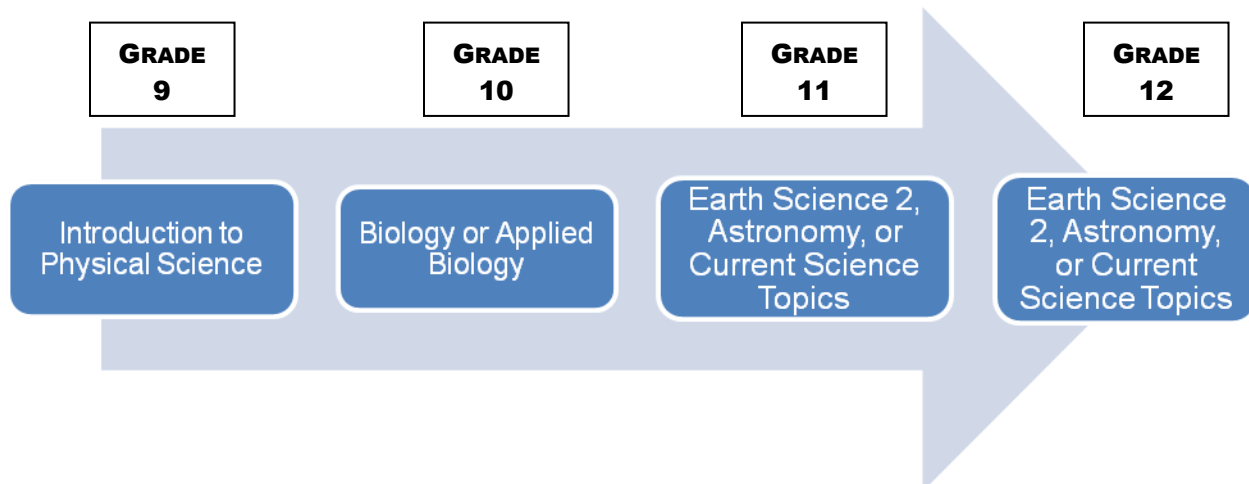

Note: ALL students MUST also complete the one semester course Earth Science during freshman or sophomore year.

8050 PSYCHOLOGY**Semester Course**
Grade Level: 11-12
♦10 w/instr. approval**0.5 Credits**
Prerequisite: "C" or better
in U.S. History or instr.
recommendation

Includes current trends and careers, especially sleep and dream analysis, motivation and emotions, theories of personality, psychological disorders, and treatments.

8051 PSYCHOLOGY 2**Semester Course**
Grade Level: 11-12**0.5 Credits**
Prerequisite: "B" or
better in Psychology or
instr. recommend.

Includes the areas of Biology & Behavior, Sensation & Perception, Learning, Memory, Thinking & Language, Intelligence, Psychological Tests, and Sports Psychology. Also includes a semester-long behavioral modification project.

8070 ADVANCED PLACEMENT (AP) PSYCHOLOGY***Year Course**
Grade Level: 11-12
1 Credit

The purpose of the course is to introduce the systematic and scientific study of the behavior and mental processes of human beings and other animals. Included will be a study of the major subfields of psychology: Body and Behavior, Altered States of Consciousness, Sensation and Perception, Learning, Memory, Thinking, Motivation, Personality, and Psychological Disorders. Students also learn about the ethics and methods psychologists use in their science and practice.

8055 SOCIOLOGICAL DYNAMICS OF THE INDIVIDUAL & FAMILY (GRADUATION REQ.)**Semester Course**
Grade Level: 12
0.5 Credits

Designed to assist individuals in achieving life satisfaction through responsible participation as adults in the home and community. Emphasizes realistic expectations of marriage, parenting, and family life, etc.

8065 ECONOMICS**Semester Course**
Grade Level: 11-12
0.5 Credits

Covers resources, the factors of production, the roles of competition, business and government, supply and demand, comparative economic systems, and the role of the consumer in the U.S. economy.

8075 AMERICAN JUDICIAL SYSTEM (CIVIL LAW)**Semester Course**
Grade Level: 11-12
0.5 Credits

Introduction to basic areas of Civil Law, including contracts, domestic law, personal injury, and trusts and estates. Students will study and draft legal documents as well as participate in a mock trial.

8080 AMERICAN JUDICIAL SYSTEM (CRIMINAL LAW)**Semester Course**
Grade Level: 11-12
0.5 Credits

Students examine crime, the structure and applications of criminal law and the judicial system. Study Supreme Court cases on search and seizure, Miranda, jury trial, and others. Students will participate in a mock trial. *Articulates with Elgin Community College CRJ 101*

HONORS/AP SOCIAL STUDIES SUGGESTED COURSE FLOW

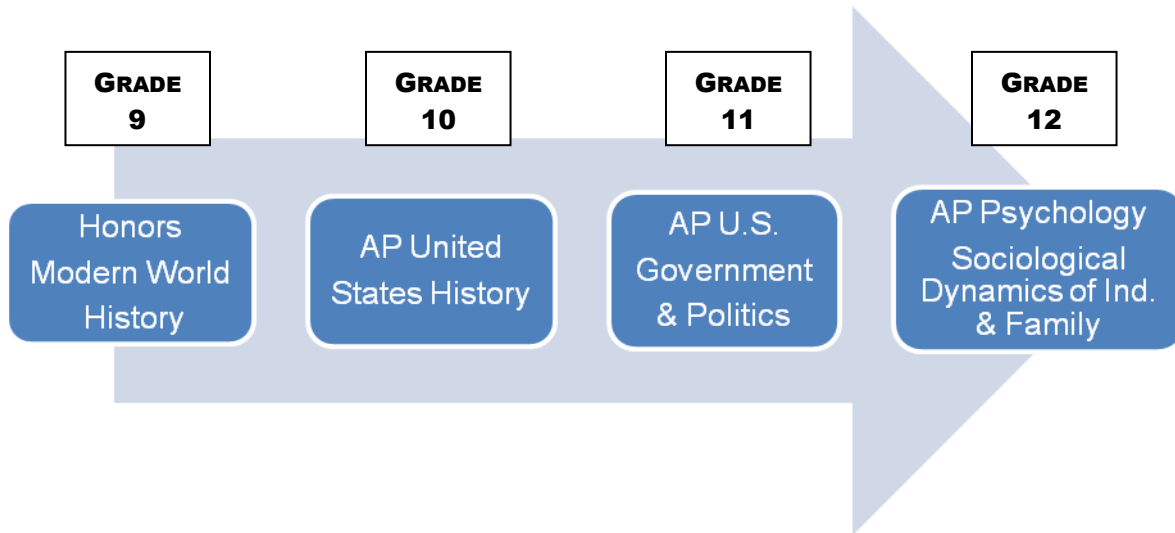

Note: All students must also take, at least, one social studies elective during high school. Elective options are: Advanced Placement (AP) Psychology (11-12 only), Adventures in Social Studies (9-10), Civil Law (11-12), Criminal Law (11-12), Economics (11-12), Psychology (11-12, 10 w/instructor permission), Sociology (11-12, 10 w/instructor permission), U.S. Historical Perspectives in Cinema (11-12), and World Historical Perspectives in Cinema (11-12).

COLLEGE PREPARATORY SUGGESTED SOCIAL STUDIES COURSE FLOW

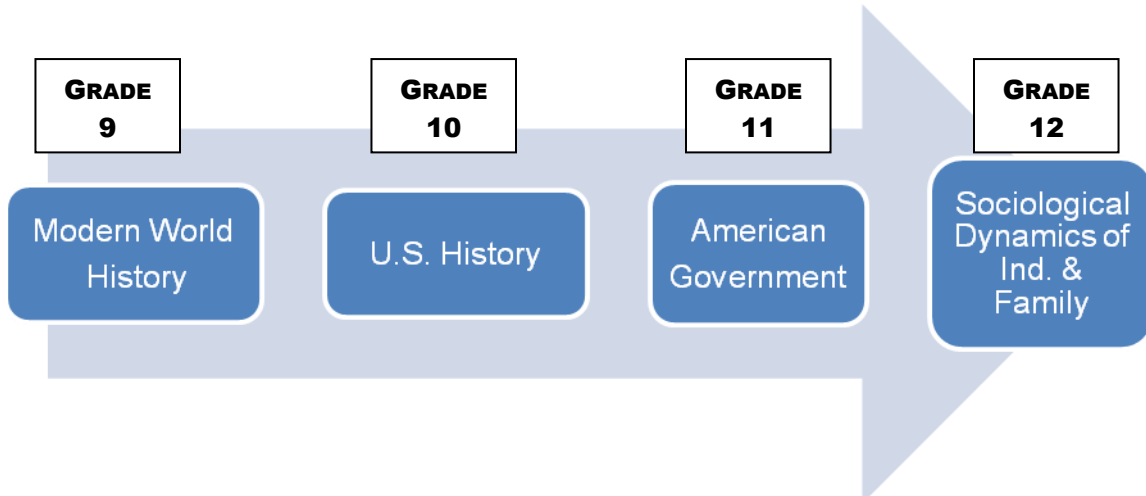

Note: All students must also take, at least, one social studies elective during high school. Elective options are: Advanced Placement (AP) Psychology (11-12 only), Adventures in Social Studies (9-10), Civil Law (11-12), Criminal Law (11-12), Economics (11-12), Psychology (11-12, 10 w/instructor permission), Sociology (11-12, 10 w/instructor permission), U.S. Historical Perspectives in Cinema (11-12), and World Historical Perspectives in Cinema (11-12).

ELGIN COMMUNITY COLLEGE PARTNERSHIP FOR COLLEGE AND CAREER SUCCESS PROGRAMS (FORMERLY TECH PREP)

COURSE OFFERINGS

9250 AUTOMOTIVE SERVICE TECHNOLOGY TP
Year Course 4 Credits
Grade Level: 11-12 Prerequisite: See Page 5

A series of three courses (Automotive Engine Service & Repair, Automotive Suspension & Wheel Alignment, and Automotive Brake Systems) taught at ECC. Students receive both high school and college credit.

9255 ENGINEERING/CAD TP†
Year Course 4 Credits
Grade Level: 12 Prerequisite: See Page 5

A series of four courses (Introduction to SolidWorks, General Engineering Drawing, Advanced Concepts in SolidWorks, and Industrial Design Problems) taught at ECC. Students receive both high school and college credit.

9265 GRAPHIC DESIGN TP†
Year Course 4 Credits
Grade Level: 12 Prerequisite: See Page 5

A series of courses (Introduction to Digital Design, Introduction to Graphic Design, Conceptual Visualization, and Layout Design) taught at ECC within this subject area. Students receive both high school and college credit.

**9270 HEATING, VENTILATION,
AIR CONDITIONING TP**
Year Course 4 Credits
Grade Level: 11-12 Prerequisite: See Page 5

A series of courses (Air Conditioning & Refrigeration 1, Basic Electricity & HVACR Controls, Refrigerant Recovery Certification, Air Conditioning & Refrigeration 2, and Basic Heating Gas/Oil) taught at ECC. Students receive both high school and college credit.

9275 INDUSTRIAL MANUFACTURING TECH. TP
Year Course 4 Credits
Grade Level: 12 Prerequisite: See Page 5

A series of courses (Industrial Manufacturing Tech 1, 2, 3, and 4) taught at ECC. Students receive both high school and college credit.

9280 EARLY CHILDHOOD EDUCATION TP
Year Course 4 Credits
Grade Level: 12 Prerequisite: See Page 5

A series of courses (Introduction to Early Childhood Education, Curriculum Planning/Young Children, Health & Nutrition for Children, and Development of Young Children) taught at ECC. Students receive both high school and college credit.

9285 OFFICE ADMINISTRATION TECHNOLOGY TP
Year Course 4 Credits
Grade Level: 12 Prerequisite: See Page 5

A series of courses (Software Applications for the Office, Business Communications, Word Processing Applications 1 & 2, Spreadsheet 1, and Applied Business Language Skills) taught at ECC. Students receive both high school and college credit.

9290 PARALEGAL TP†
Year Course 4 Credits
Grade Level: 12 Prerequisite: See Page 5

A series of courses (Legal Environment of Business, Introduction to Computers, Introduction to Legal Technology, and American Government) taught at ECC. Students receive both high school and college credit.

9295 ACCOUNTING TP†
Year Course 4 Credits
Grade Level: 12 Prerequisite: See Page 5

A series of courses (Introductory Accounting, Business Mathematics, Financial Accounting, and Business Communications) taught at ECC. Students receive both high school and college credit.

9300 WELDING FABRICATION TECHNOLOGY TP
Year Course 4 Credits
Grade Level: 12 Prerequisite: See Page 5

A series of courses (Welding 1, 2, and 3, and MIG Welder Qualification) taught at ECC. Students receive both high school and college credit.

9310 ENTREPRENEURSHIP TP
Year Course 4 Credits
Grade Level: 12 Prerequisite: See Page 5

A series of courses (Entrepreneurship Seminar 1, Small Business Management, Marketing, and Business Plan Writing) taught at ECC. Students receive both high school and college credit.

9315 CULINARY ARTS TP
Year Course 4 Credits
Grade Level: 12 Prerequisite: See Page 5

A series of courses (Culinary Techniques, Food Production 1 & 2, and Applied Food Service Sanitation) taught at ECC. Students receive both high school and college credit. Courses are held in the evening.

9320 PASTRY TP
Year Course 4 Credits
Grade Level: 12 Prerequisite: See Page 5

A series of courses (Baking I, Baking Techniques, Applied Food Service Sanitation, and Advanced Pastry) taught at ECC. Students receive both high school and college credit.

9325 FIRE SCIENCE & SAFETY TP
Year Course 4 Credits
Grade Level: 12 Prerequisite: See Page 5

A series of courses (Introduction to Fire Science, First Aid & Safety, Fire Suppression, and Fire Protection Systems) taught at ECC. Students receive both high school and college credit.

9330 CRIMINAL JUSTICE TP
Year Course 4 Credits
Grade Level: 12 Prerequisite: See Page 5

A series of courses (Introduction to Criminal Justice, Juvenile Justice, Introduction to Corrections, and Crime Prevention) taught at ECC. Students receive both high school and college credit.

9335 CLINICAL LABORATORY TECHNOLOGY TP†
Year Course 4 Credits
Grade Level: 12 Prerequisite: See Page 5

A series of courses (Principles of Biology, Introduction to Healthcare Vocabulary, Phlebotomy, Clinical Lab Assistant Skills 1 & 2) taught at ECC. Students receive both high school and college credit.

9340 BASIC NURSE ASSISTANT TP†
Year Course 4 Credits
Grade Level: 12 Prerequisite: See Page 5

A series of courses (Basic Nurse Assistant Training Program, Nutrition for Today, and Principles of Sociology) taught at ECC. Students receive both high school and college credit.

9345 HEALTH PROFESSIONS: PREPARATION FOR NURSING, PHYSICAL THERAPY ASSISTANT, SURGICAL TECHNOLOGY TP†
Year Course 4 Credits
Grade Level: 12 Prerequisite: See Page 5

A series of courses (Principles of Biology, Introduction to Healthcare Vocabulary, and Human Anatomy and Physiology I) taught at ECC. Students receive both high school and college credit.

9355 COMPUTER & INFORMATION SCIENCE TP†
Year Course 4 Credits
Grade Level: 12 Prerequisite: See Page 5

A series of courses (Introduction to Computers, Computer Operating Systems/Microsoft, Introduction to Programming and Computer Hardware) taught at ECC. Students receive both high school and college credit.

9360 RESTAURANT MANAGEMENT TP
Year Course 4 Credits
Grade Level: 12 Prerequisite: See Page 5

A series of courses (Introduction to the Hospitality Industry, Hospitality Supervision, Applied Food Services Sanitation, Hospitality Law, and Quantity Food

Purchasing) taught at ECC. Students receive both high school and college credit.

9365 MANAGEMENT TP
Year Course 4 Credits
Grade Level: 12 Prerequisite: See Page 5

A series of courses (Introduction to Business, Business Communication, Spreadsheet Software - Excel, Principles of Management, Personal Information Management, and Business Mathematics) taught at ECC. Students receive both high school and college credit.

9370 MARKETING & RETAIL MANAGEMENT TP
Year Course 4 Credits
Grade Level: 12 Prerequisite: See Page 5

A series of courses (Business Mathematics, Sales, Marketing, and Introduction to Business) taught at ECC. Students receive both high school and college credit.

9375 INTEGRATED SYSTEMS TECHNOLOGY/ MAINTENANCE TECHNOLOGY TP
Year Course 4 Credits
Grade Level: 12 Prerequisite: See Page 5

A series of courses (Programmable Controllers 1, Programmable Controllers 2, Advanced Programmable Controllers, and Basic Mechanical Drives) taught at ECC. Students receive both high school and college credit.

9385 WEB DESIGN TP†
Year Course 4 Credits
Grade Level: 12 Prerequisite: See Page 5

A series of courses (Introduction to Digital Design, Web Basics (HTML), Color Theory, and Web Site Design) taught at ECC. Students receive both high school and college credit.

9390 MULTIMEDIA DESIGN TP†
Year Course 4 Credits
Grade Level: 12 Prerequisite: See Page 5

A series of courses (Introduction to Digital Design, Introduction to Multimedia Design, Color Theory, and Motion Graphics & Effects) taught at ECC. Students receive both high school and college credit.

9395 PUBLIC SAFETY COMMUNICATIONS TP
Year Course 4 Credits
Grade Level: 12 Prerequisite: See Page 5

A series of courses (Public Safety Telecommunicator, Introduction to Corrections, and Crime Prevention) taught at ECC. Students receive both high school and college credit.

†Indicates additional prerequisites for this program. Please see Page 5 or your counselor for details.

NOTE: Specific program courses are subject to change at ECC's discretion.

FOX VALLEY CAREER CENTER PROGRAMS

COURSE OFFERINGS

9000 AUTOMOTIVE TECHNOLOGY 1

Year Course 3 Credits
Grade Level: 11-12 **Prerequisite:** Tech/Pre-Eng.

Introduces students to the wide field of auto repair. Areas of study include electrical systems, tune-ups, wheel alignment, lubrication, brakes, fuel systems, cooling systems, and basic computer troubleshooting. *Articulates with ECC AUT 151.*

9001 AUTOMOTIVE TECHNOLOGY 2

Year Course 3 Credits
Grade Level: 12 **Prerequisite:** Auto Tech 1

Advanced instruction in computer engine testing and diagnostics, cylinder head service, lower engine rebuilding procedure, and air conditioning service and repair. *Articulates with ECC AUT 152.*

9005 EARLY CHILDHOOD EDUCATION

Year Course 3 Credits
Grade Level: 11-12 **Prerequisite:** Child Growth

Provides students with the knowledge and practical experience needed to develop skills required to work effectively with young children. Students will work in Small World Learning Center. *Articulates with ECC ECE 124.*

9006 EARLY CHILDHOOD EDUCATION 2

Year Course 3 Credits
Grade Level: 12 **Prerequisite:** Early Childhood Ed. 1 & School-Age Child Development

Emphasis is placed on working with infants, children with special needs, and elementary school children. Opportunities to work as interns in the infant-toddler room or as interns in elementary schools in the community.

9025 RESIDENTIAL/COMMERCIAL ELECTRICIAN 1

Year Course 3 Credits
Grade Level: 11-12 **Prerequisite:** Tech/Pre-Eng.

Covers a variety of wiring practices involving the use of Romex cable and conduit to construct most of the lighting and receptacle outlet circuits found in modern homes.

9026 RESIDENTIAL/COMMERCIAL ELECTRICIAN 2

Year Course 3 Credits
Grade Level: 12 **Prerequisite:** Electrician 1

Heavy emphasis on conduit work, more complex circuits and components, and much emphasis on the National Electrical Code rules. Also included is 200 amp service entrance meter box and circuit breaker panel wiring.

9035 GRAPHIC COMMUNICATIONS 1

Year Course 3 Credits
Grade Level: 11-12 **Prerequisite:** Multimedia Prod.

Emphasis is placed upon the theories and processes that make up production, printing. Instruction and practice in offset printing, digital workflow, and screen printing.

9036 GRAPHIC COMMUNICATIONS 2

Year Course 3 Credits
Grade Level: 12 **Prerequisite:** Graphic Communications 1

Extension of Graphic Communications 1 in the production-oriented environment. Course content includes further career education opportunities, planning for the future, job seeking skills, personal development.

9040 HEALTH OCCUPATIONS – CERTIFIED NURSING ASSISTANT (CNA)

Year Course 3 Credits
Grade Level: 11-12

Introduces students to various health concepts and trains them to work as a Certified Nursing Assistant (CNA). Upon completion of the program, the student is prepared to take the Nurse Aide Training Competency Exam, which allows for certification from the Illinois Department of Public Health. *Articulates with ECC NUR 105*

9045 HEALTH OCCUPATIONS – EXPLORING MEDICAL CAREERS (EMC)

Year Course 3 Credits
Grade Level: 11-12

Designed for students who are interested in exploring health-related career opportunities. Students learn anatomy/physiology and a variety of medical terms, techniques, and procedures while visiting various health care facilities for a first-hand view of careers. Students must provide their own transportation.

9055 HORTICULTURE 1: PRODUCTION & MANAGEMENT

Year Course 3 Credits
Grade Level: 11-12 **Prerequisite:** Basic Ag. Science

Offers instruction in floriculture, landscaping, plant management, and agriculture biotechnology. Units of study include plant identification, greenhouse management, culture of greenhouse crops, care and handling of cut flowers, and floral design.

9056 HORTICULTURE 2: LANDSCAPING & TURF MGMT.

Year Course 3 Credits
Grade Level: 12 **Prerequisite:** Horticulture 1

Advanced course focuses on the landscape, nursery, and turf segments of the horticulture industry. Includes identifying landscape plants, designing landscape plans, hardscape construction techniques, and installing landscape plants.

9060 SMALL ENGINES

Year Course **3 Credits**
Grade Level: 11-12 **Prerequisite: Tech/Pre-Eng.**

Emphasis is placed on the parts and operation of both two and four cycle engines, ranging from lawn mowers to high performance dirt bikes, snowmobiles, jet skis, and ATV's. *Articulates with ECC AUT 100.*

9061 SMALL ENGINES 2

Year Course **3 Credits**
Grade Level: 12 **Prerequisite: Small Engines**

Emphasis is placed on further developing skills learned in Small Engines 1. Students have more time for projects as well as live jobs from customers. Students are also required to diagnose mechanical and electrical problems and make proper repairs in a minimum amount of time.

9070 BUILDING TRADES

Year Course **3 Credits**
Grade Level: 11-12 **Prerequisite: Tech/Pre-Engineering, Woods 1 & 2**

Students will be introduced to various areas in home construction. Framing, roofing, drywall installation and carpentry will be the major focus of this course. Students must provide their own transportation to and from St. Charles North High School and provide and maintain typical carpentry hand tools.

9071 BUILDING TRADES 2

Year Course **3 Credits**
Grade Level: 12 **Prerequisite: Bldg. Trades**

Students will further develop and refine their construction skills. In addition to classroom participation, students gain practical experience constructing a single-family home, from pouring the foundation to framing and exterior work.

9080 WELDING 1

Year Course **3 Credits**
Grade Level: 11-12 **Prerequisite: Tech/Pre-Eng.**

This introductory course is designed to help students master skills in the following areas: shielded arc welding, gas metal arc welding, tungsten metal arc welding, oxyacetylene welding, bronzing, flame cutting and the fundamentals of weld shop fabrication. Students must supply their own safety glasses, heavy gloves, work shirt, and necessary tools/materials. *Articulates with ECC WEL 101.*

9081 WELDING 2

Year Course **3 Credits**
Grade Level: 12 **Prerequisite: Welding 1**

This course will utilize the concepts practiced in Welding 1 with more in-depth specialization. A higher level of competency is expected. Course material will be developed around problem solving fabrication equipment, operational procedures, production layout, technical function, and necessary tools/materials. *Articulates with ECC WEL 102.*

9085 FIRE SCIENCE 1

Year Course **3 Credits**
Grade Level: 11-12

Students cover fire suppression activities as prescribed by the IFSTA Essential Manual. In addition, they will cover the First Responder course and, if successful, they will become certified as a First Responder. *Articulates with ECC FSS 101.*

9090 FIRE SCIENCE 2

Year Course **3 Credits**
Grade Level: 12 **Prerequisite: Fire Science 1**

Study and practice of advanced techniques used in fire fighting. Topics include personal safety, ladders, fire hose and appliances, water supply, nozzles and fire streams, rescue, communications, sprinkler systems, fire prevention, public fire education, and fire cause determination. *Articulates with ECC FSS 202.*

9095 EMERGENCY MEDICAL TECHNICIAN (EMT)

Year Course **3 Credits**
Grade Level: 12

Prepares students to become competent, entry-level EMT Basics in order to serve in volunteer and/or professional career positions in the State of Illinois and area communities.

Available to students who plan to go into the health care or fire science fields, or another area of emergency medical services. Upon completion of EMT Basic, the student is prepared to take the EMT Basic Competency Exam which allows for certification from the IDPH.

9100 COMPUTER TECHNOLOGY – GAME PROGRAMMING & TECHNOLOGIES

Year Course **3 Credits**
Grade Level: 12 **Prerequisite: PC Maint., Repair & Networking or Web Develop. or equiv. high school course or prof. test.**

Students will study various game genres, purposes, and platforms. Students will have an opportunity to experience the many careers associated with game development including most aspects of game design and development. *Articulates with ECC CIS 147.*

9410 COSMETOLOGY 1

Year Course **4 Credits**
Grade Level: 11-12

Divided into several units of study that includes hair shaping, hair styling, draping, shampooing, blow dry styling, manicuring, facials, waving, and sanitation. Chemistry and professional ethics will be taught in conjunction with the above units. Students required to provide their own transportation to the training schools, buy uniforms, shoes, cosmetology kit, and pay the required registration and lab fees.

9415 COSMETOLOGY 2

Year Course **4 Credits**
Grade Level: 12 **Prerequisite: Cosmetology 1**

Students continue work to obtain the required 1500 hours and meet state requirements for licensing testing. After completing course, students may take the Cosmetology Licensing Exam and become a licensed cosmetologist.

